

TOSHIBA

SMMS 7
SUPER MODULAR MULTI SYSTEM

"SMMS -7 the senses of cooling"



Air Conditioning for large building

 *Better Air Solutions*

SMMS-7**Introduction**

Toshiba air conditioning vision	1
7 Senses of smartness	2-3
Product line up	4

7 Smart features

Higher energy efficiency	5
Space saving and light weight	6
Wider ambient operation	7
Environmentally - oriented	7
High reliability	8-9
Design flexibility	10-11
Easy installation and maintenance	12-13

Outdoor units

Outdoor units line-up	14-15
Outdoor units specifications	16-23
Outdoor units external view drawings	24-27

Indoor units

Indoor units line-up for SMMS-7	28-29
4-way air discharge cassette type	30-31
Compact 4-way cassette type	32-33
2-way air discharge cassette type	34-35
1-way air discharge cassette type	36-37
Slim duct type	38-39
Super slim duct type	40-41
Concealed duct high static pressure type	42-43
Concealed duct type	44-45
Ceiling type	46-47
High-wall type (series 7)	48
High-wall type (large capacity)	49
Floor standing concealed type	50
Floor standing cabinet type	51
Console type	52
Floor standing type	53
Large capacity floor standing duct type	54
Large capacity floor standing direct type	55
DX-COIL Interface	56-58
Fresh air intake indoor unit type	59
Air-to-Air heat exchanger with DX-coil	60-61
Air-to-Air heat exchange (stand alone unit)	62-63
Indoor unit accessories for SMMS-7	64-65

Remote controllers	66-69
---------------------------	-------

Building management systems	70-71
------------------------------------	-------

Open network systems	72-73
-----------------------------	-------

Application controls	74-76
-----------------------------	-------

Mini SMMS-7**Features**

Higher energy savings	78
Higher comfort and ease	79
Higher installation and flexibility	80

Outdoor Units

Outdoor units line-up	81
Outdoor units specifications	82-84
Outdoor drawings	85-88

Safety precautions	89
---------------------------	----

TOSHIBA AIR CONDITIONING VISION

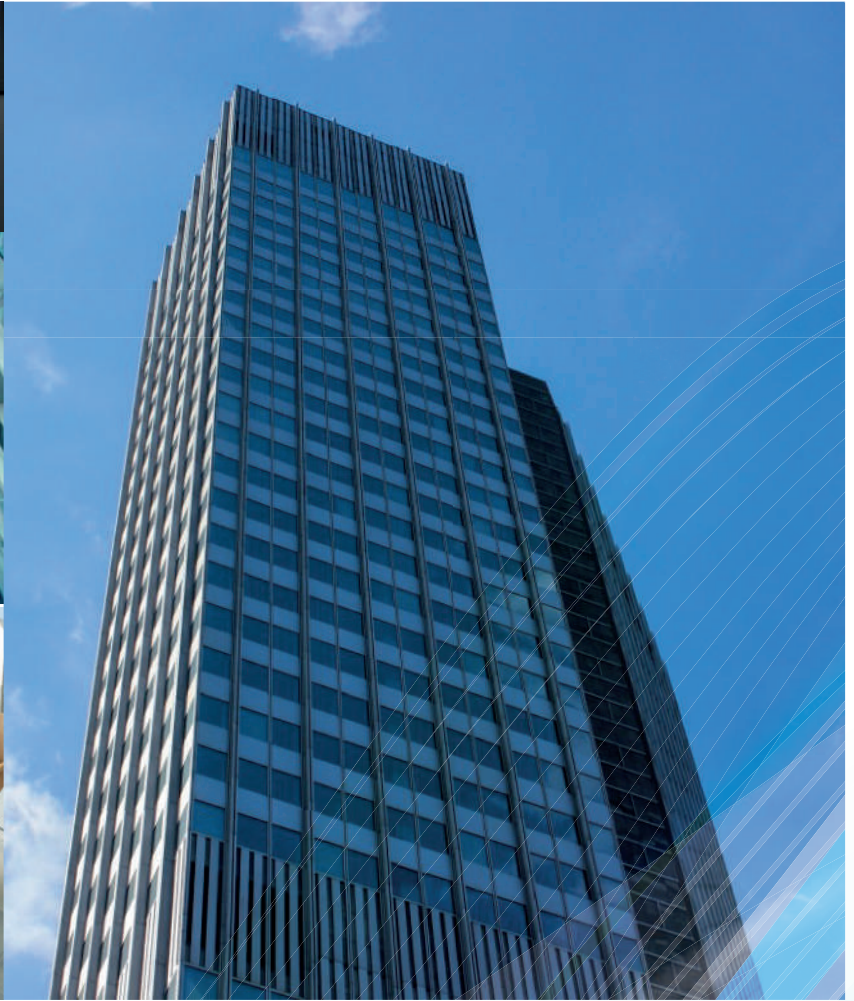

Better Air Solutions

Through our commitment to world-class efficiency, versatile scalability and leading quality, Toshiba Air Conditioning advances leading-edge technologies to find the most forward-thinking solutions possible for your world.



7

Senses

Because understand your real needs, we have in air conditioning, which we have innovately this VRF is cooling optimized for hot and humid

»»» Sense of efficiency

Higher energy efficiency

»»» Sense of care

Environmentally - oriented

»»» Sense of space

Space saving and light weight

»»» Sense of environment

Wider ambient



of smartness

we searched for and finally found 7 senses of smartness developed into the most advanced technologies SMMS-7 and temperature.

»»» Sense of convenience

Easy installation and maintenance

»»» Sense of flexibility

Design flexibility

»»» Sense of strength

High reliability



durance
operation



"SMMS-7 the senses of cooling"



"SMMS-7 the senses of cooling"



PRODUCT LINE UP

Standard model

Equivalent HP	8HP	10HP	12HP	14HP	16HP	18HP	20HP	22HP	24HP
Appearance									
External dimensions (H x W x D)	1,800 x 990 x 780mm				1,800 x 1,210 x 780mm				1,800 x 1,600 x 780mm
Refrigerant type	R410A								

High efficiency model

Equivalent HP	14HP
Appearance	
External dimensions (H x W x D)	1,800 x 1,210 x 780mm
Refrigerant type	R410A

Product line up

	8HP	10HP	12HP	14HP	16HP	18HP	20HP	22HP	24HP	26HP	28HP	30HP	32HP	34HP	36HP	38HP	40HP	42HP	44HP	46HP	48HP	50HP	52HP	54HP	56HP	58HP	60HP	
Standard model	●	●	●	●	●	●	●	●	●	●	●	●	●	●	●	●	●	●	●	●	●	●	●	●	●	●	●	●
High efficiency model				●	●	●	●	●	●	●	●	●	●	●	●	●	●	●	●	●	●	●	●	●	●	●	●	●

Sense of efficiency

Higher energy efficiency

Full load EER

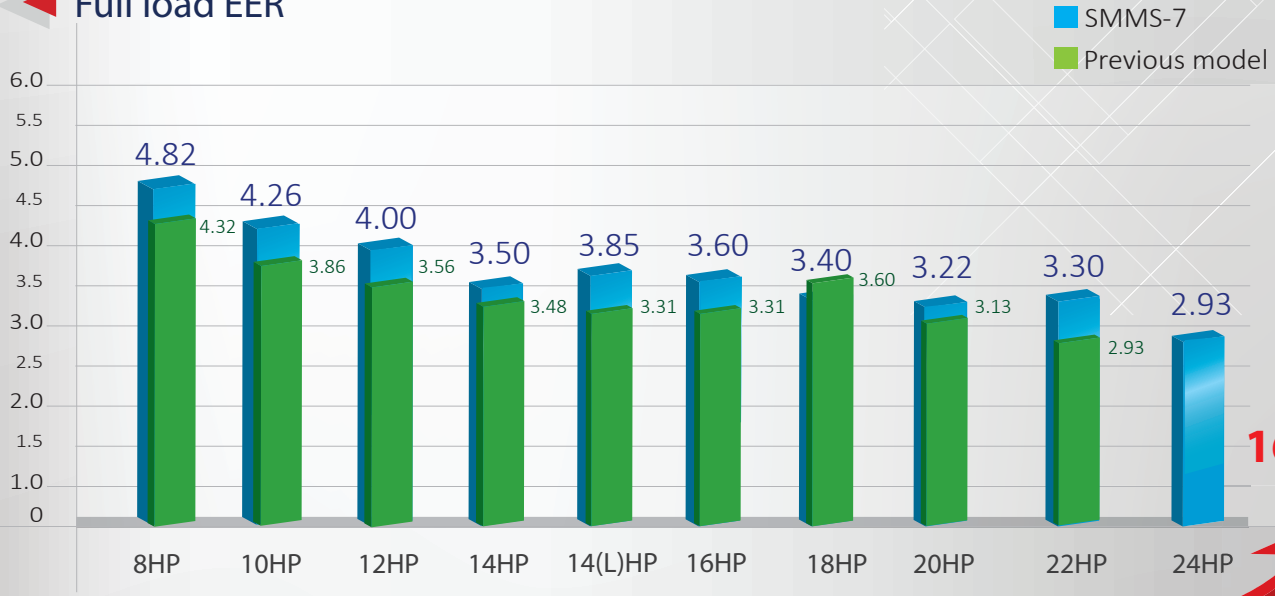

Max 16% UP!

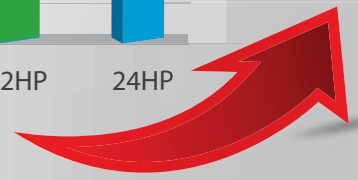

50% Part load EER

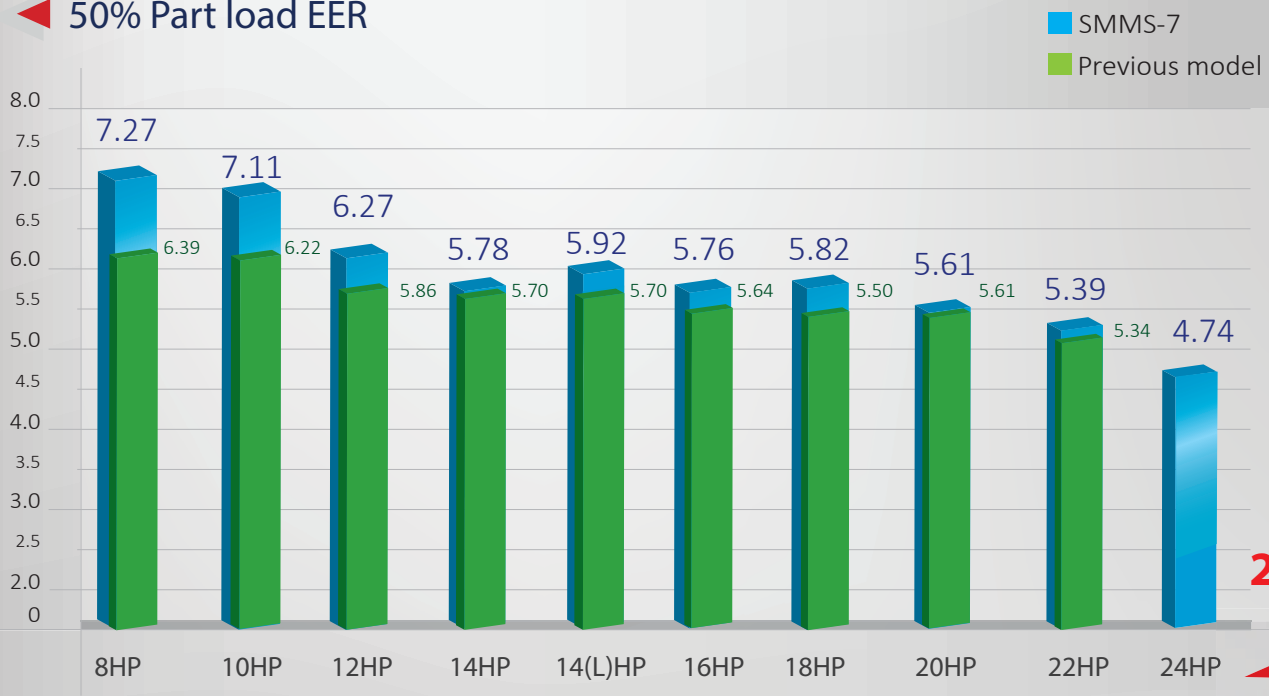

Max 26% UP!

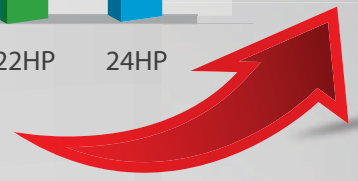

»»» Sense of space

Space saving and light weight

◀ 20 HP Model



Previous model

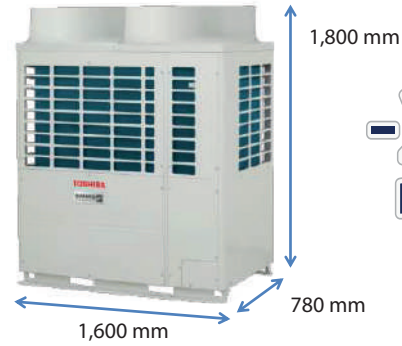

-24%
Reduced
space saving

◀ 24 HP Model

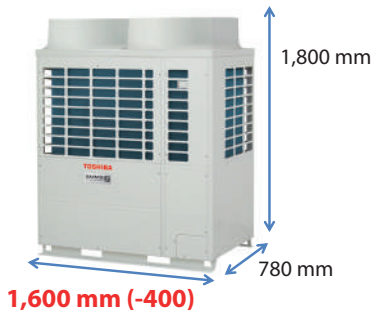

Previous model

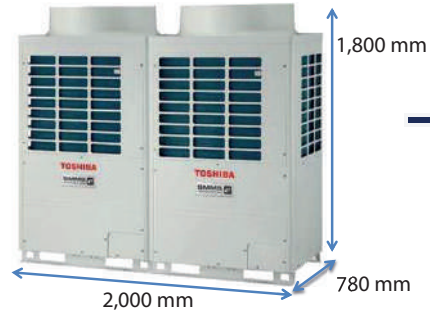

-20%
Reduced
space saving

◀ 60 HP Combination model

The new compact design not only reduce the installation foot print, but also reduce the time to deliver and install



Previous model



-18%
Reduced
space saving



Sense of endurance

Wider ambient operation

Outdoor temperature range

The combination of new compressor design and system controls have enabled SMMS-7 to expand its allowable operational temperature range

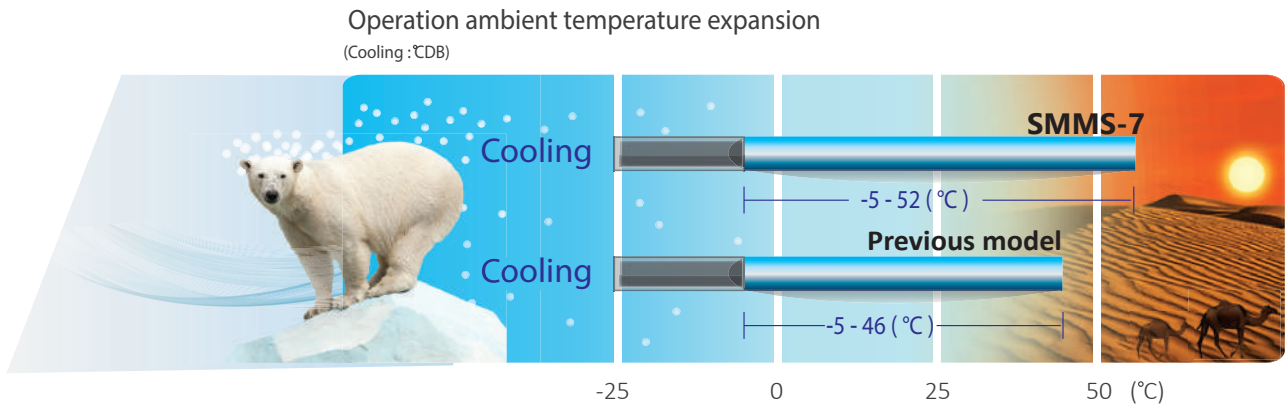

Note : Based on equivalent piping length of 7.5 m and piping height difference of 0 m.

Sense of care

Environmentally - oriented

Reduce refrigerant amount

More than 20% by delicated cooling design*

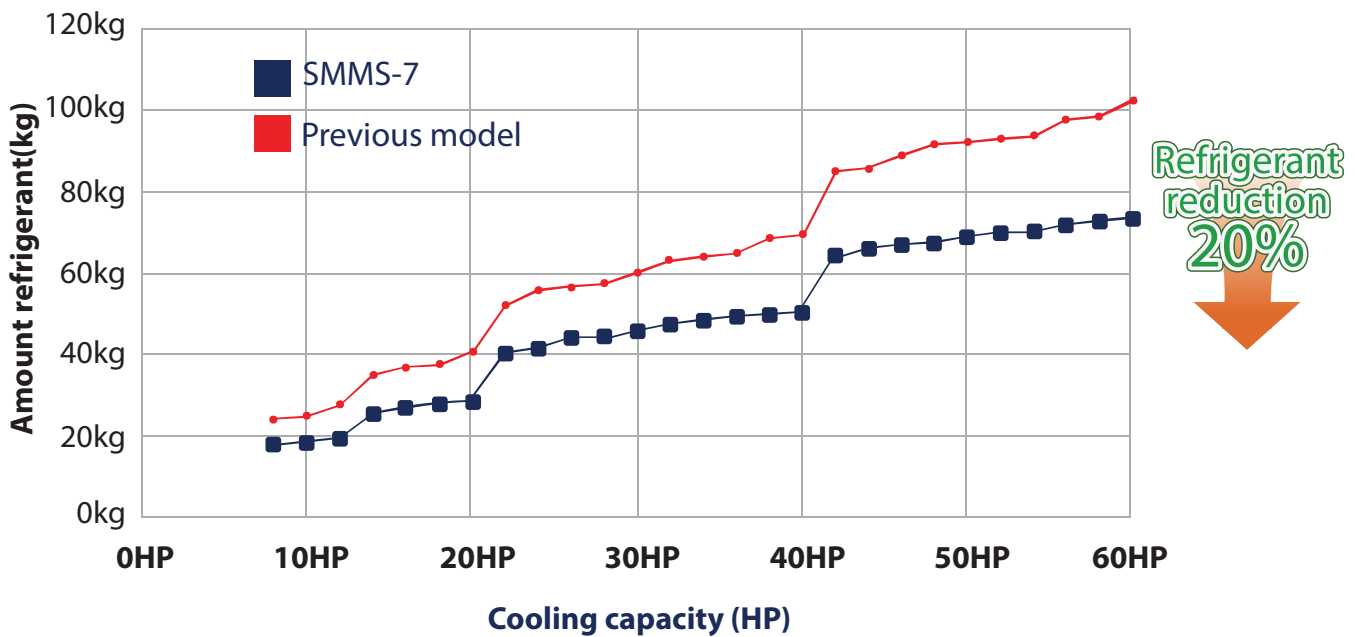

* Testing under controlled conditions.

High reliability

◀ DLC (Diamond like carbon) coated vane

Diamond Like Carbon (DLC) protection coating inside "All compressor's vane" increases efficiency and reliability

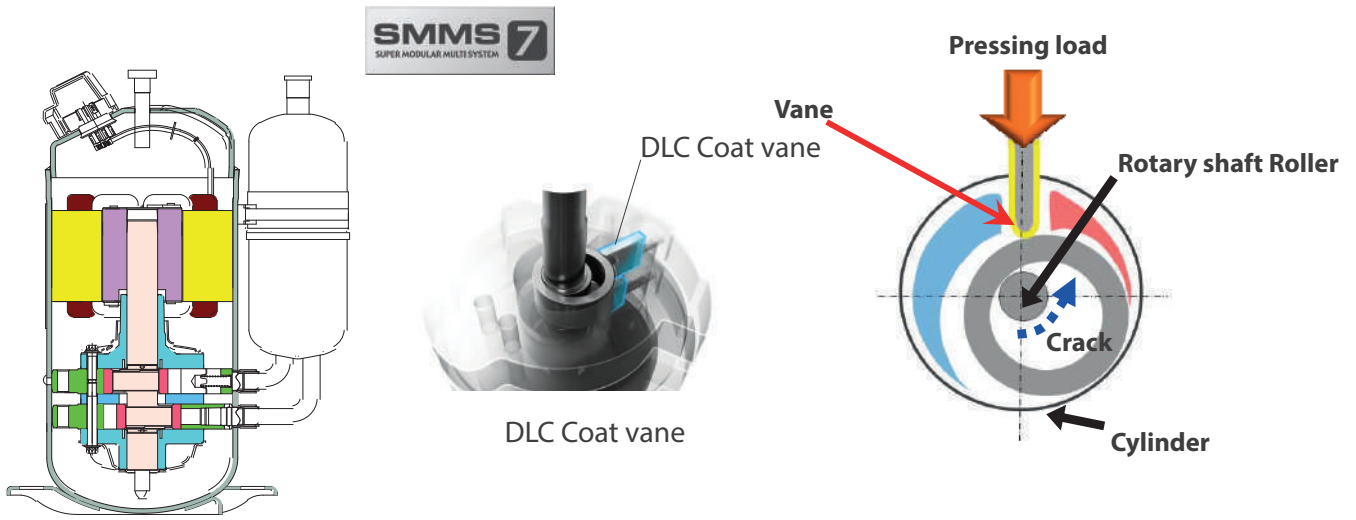

◀ 2-stage vane

2 stage vane reduce friction and results in a significant improvement in reliability and performance.

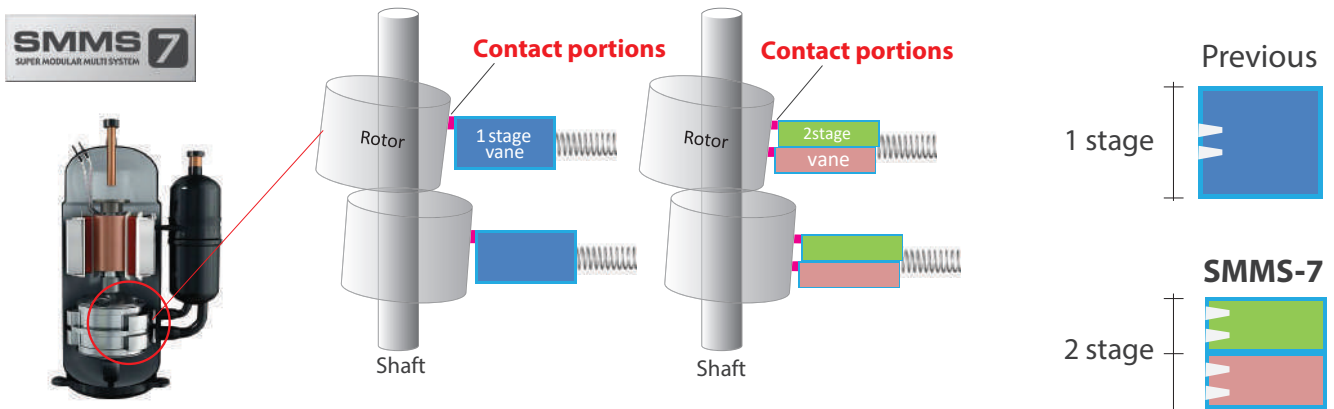

»»» Sense of strength

High reliability

◀ Small animal protection

To prevent the small animals from entering and interfering with the electronic components in the system, our new inverter box has been upgraded with additional protection, while allowing reliable operation. The inverter box is fitted with punched sheet metal & resin sheet.

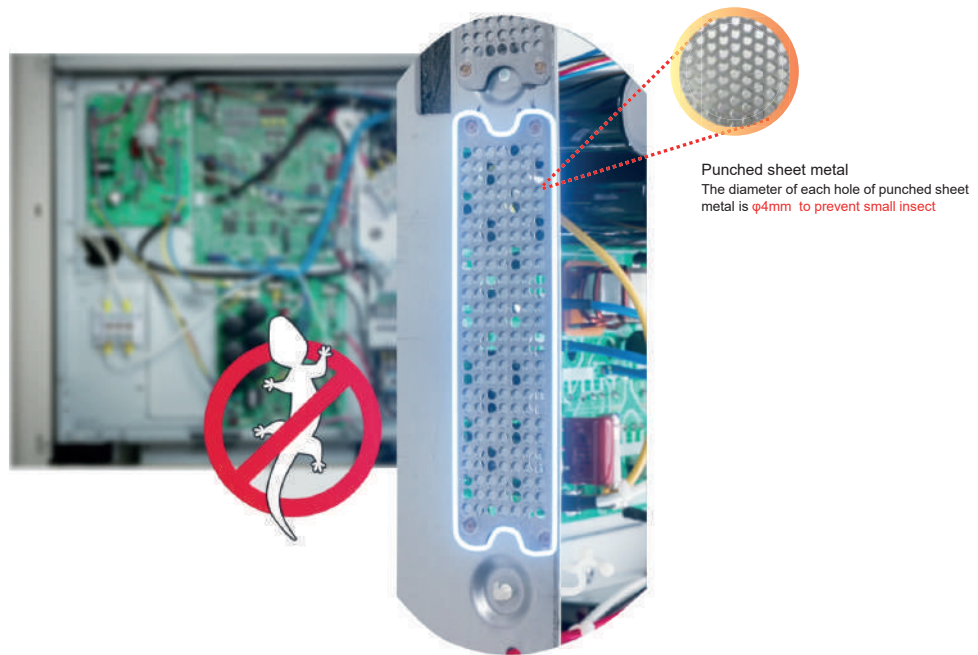

In order to stop small animals get into inverter box, SMMS-7 has resin sheet. It's preventive measure to keep them from shorting out PC boards.

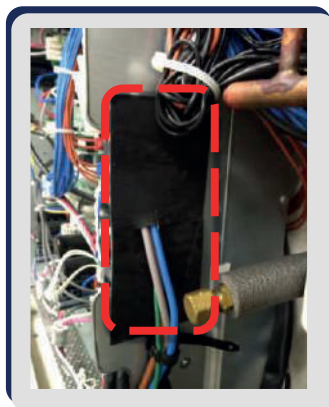

»»» **Sense** of flexibility

Design flexibility

◀ 200 % Maximum diversity

Thanks to the newly developed refrigerant circuit, the diversity of outdoor units has drastically increased. This makes it much easier to design for installations with many rooms or offices.

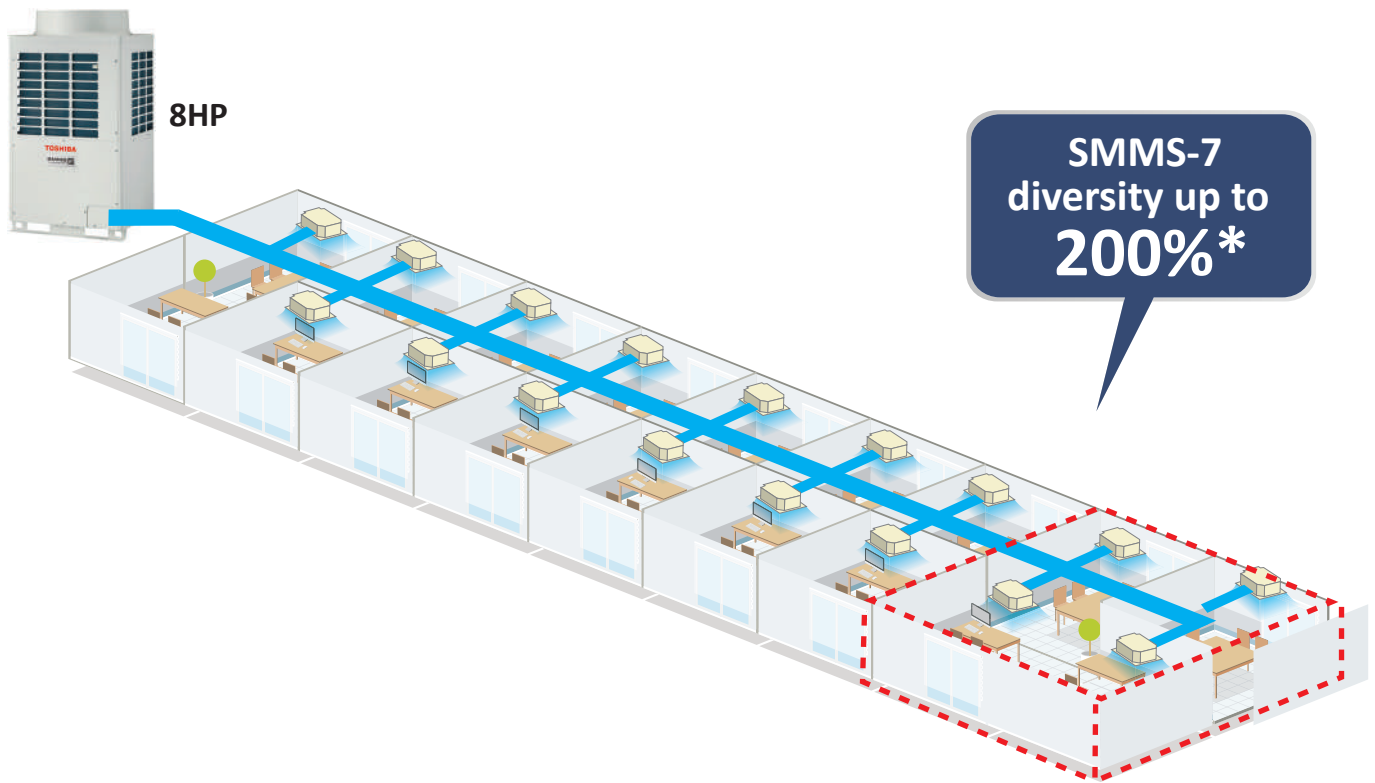

Standard model

8HP	10HP	12HP	14HP	16HP	18HP	20HP	22HP	24HP
200%	200%	200%	200%	200%	200%	200%	200%	200%

26HP	28HP	30HP	32HP	34HP	36HP	38HP	40HP
180%	180%	180%	180%	180%	180%	180%	180%

42HP	44HP	46HP	48HP	50HP	52HP	54HP	56HP	58HP	60HP
150%	150%	150%	150%	150%	150%	150%	150%	150%	150%

*Single module

»»» Sense of flexibility

Design flexibility

◀ Total piping length

Applied with Toshiba's unique and greatly improved technology, SMMS-7 can reach up to 1,000 meters maximum piping length.

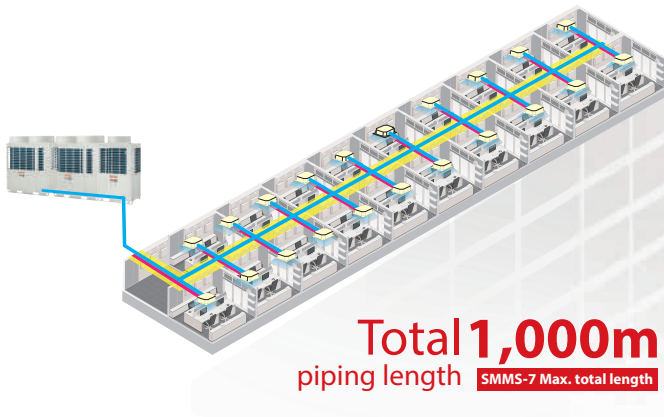

◀ Farthest pipe from 1st branch

Even more convenient with the piping distance from the first branch to the furthest indoor unit at 90 meters, increasing the flexibility of the installation within the hotel or office building.

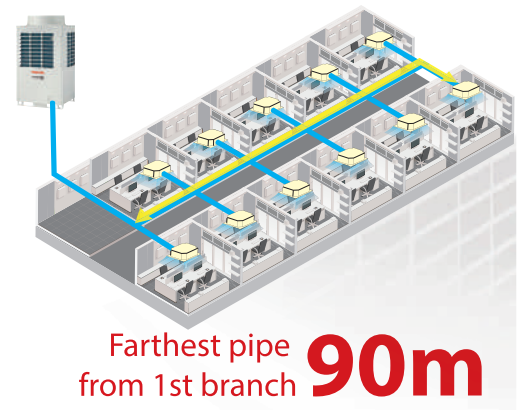

◀ Farthest equivalent length

The maximum equivalent distance between outdoor unit and farthest indoor unit tops at 235 meters, which tops the industry class.



◀ Height between indoor units

Another industry's top class is a maximum vertical distance between indoor units which reaches up to 40 meters, equal to an entire 11-storied building. SMMS-7's enhanced piping capabilities result in more benefits for the system design, installation flexibility, as well as the less installation cost.



»»» Sense of convenience

Easy installation and maintenance

◀ Installation flexibility

New system of oil management, balance pipe no longer required.

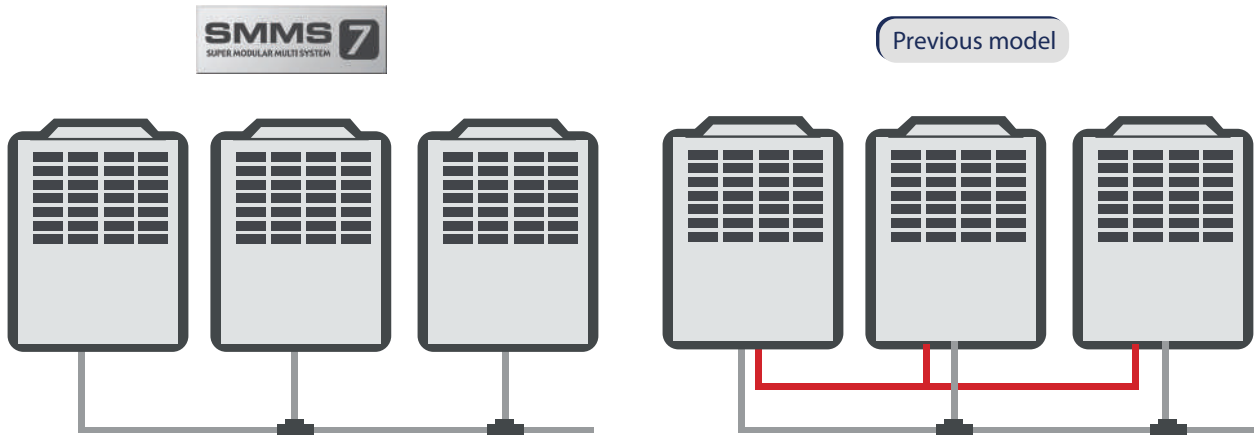

◀ Easy maintenance

Secure space for maintenance in machine area. Temperature control of liquid pipe leads to removal of liquid tank, leading to reduce refrigerant.

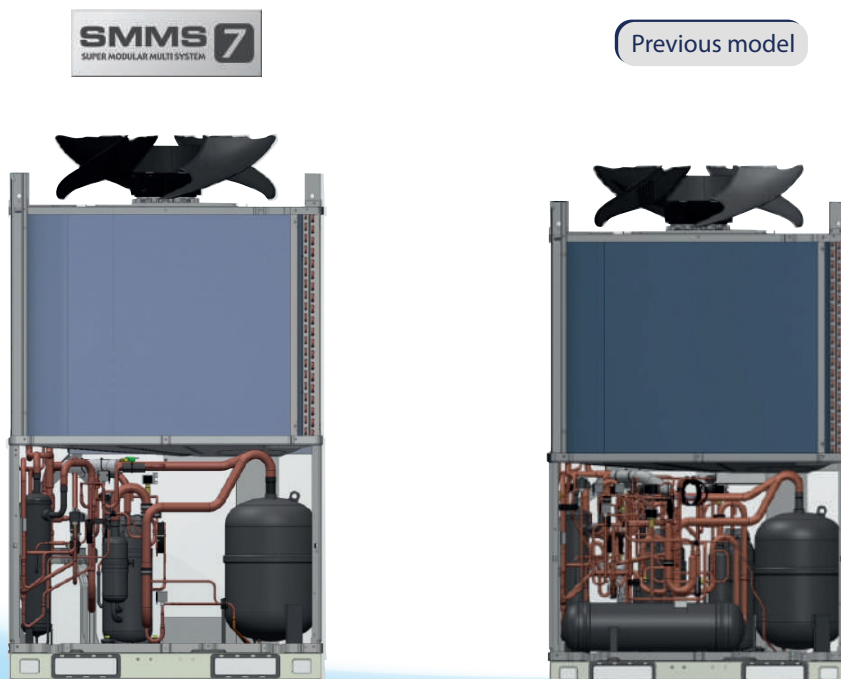

SMMS wave tool

With SMMS wave Tool, you can read and write data from outdoor unit directly on your smart phone without the needs of connecting PC or opening cabinet.

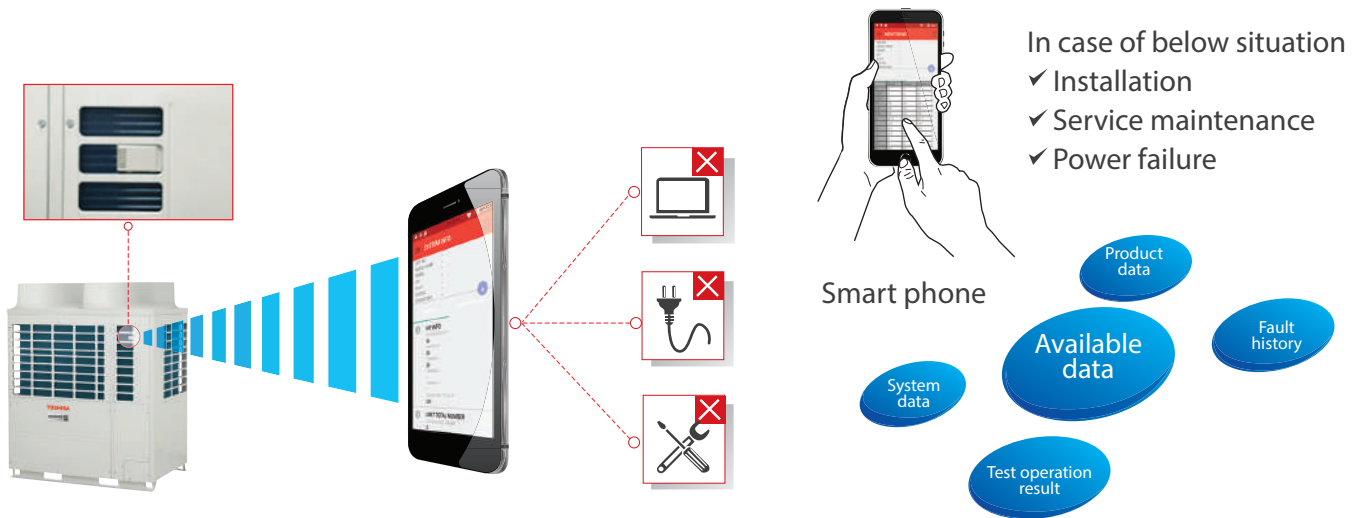

By the new smart phone application, the testing and commissioning can be done without opening the cabinet.



*Smartphone specification : Android™ OS 5.0

The external static pressure

The SMMS-7 units are suitable for challenging installations where high external static pressure performance

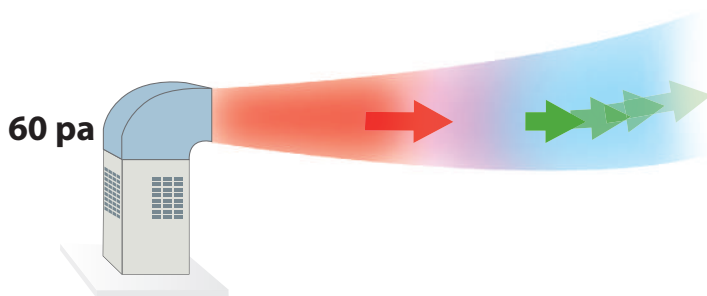



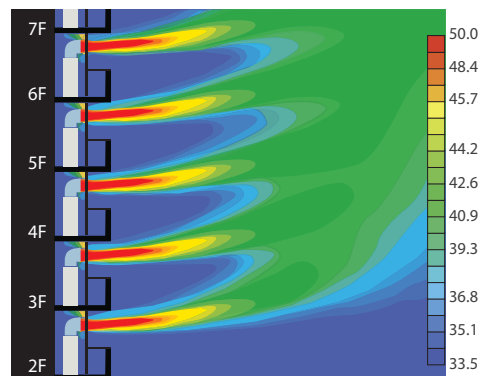







Air flow simulation diagram



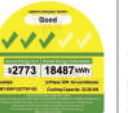

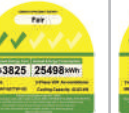
Note : This result is analytical simulation, that does not guarantee actual temperatures.



Outdoor units

Standard model

											
Capacity		8HP	10HP	12HP	14HP	16HP	18HP	20HP	22HP	24HP	
Model Name (MMY-)	50 Hz	MAP0807T8P-SG	MAP1007T8P-SG	MAP1207T8P-SG	MAP1407T8P-SG	MAP1607T8P-SG	MAP1807T8P-SG	MAP2007T8P-SG	MAP2207T8P-SG	MAP2407T8P-SG	
Cooling capacity (kW)		22.4	28.0	33.5	40.0	45.0	50.4	56.0	61.5	67.0	
Energy Label											

															
Capacity		26HP		28HP		30HP		32HP		34HP		36HP		38HP	
Model Name (MMY-)	50 Hz	AP2617T8P-SG		AP2817T8P-SG		AP3017T8P-SG		AP3217T8P-SG		AP3417T8P-SG		AP3617T8P-SG		AP3817T8P-SG	
Units in combination (MMY-)		MAP1407T8P-SG	MAP1207T8P-SG	MAP1407T8P-SG	MAP1407T8P-SG	MAP1607T8P-SG	MAP1407T8P-SG	MAP1607T8P-SG	MAP1607T8P-SG	MAP1807T8P-SG	MAP1607T8P-SG	MAP1807T8P-SG	MAP1807T8P-SG	MAP2007T8P-SG	MAP1807T8P-SG
Cooling capacity (kW)		73.5		80.0		85.0		90.0		95.4		100.8		106.4	

																					
Capacity		40HP				42HP				44HP				46HP				48HP			
Model Name (MMY-)	50 Hz	AP4017T8P-SG				AP4217T8P-SG				AP4417T8P-SG				AP4617T8P-SG				AP4817T8P-SG			
Units in combination (MMY-)		MAP2007T8P-SG	MAP2007T8P-SG	MAP1407T8P-SG	MAP1407T8P-SG	MAP1407T8P-SG	MAP1407T8P-SG	MAP1607T8P-SG	MAP1407T8P-SG	MAP1407T8P-SG	MAP1407T8P-SG	MAP1807T8P-SG	MAP1407T8P-SG	MAP1407T8P-SG	MAP2007T8P-SG	MAP1407T8P-SG	MAP1407T8P-SG				
Cooling capacity (kW)		112.0				120.0				125.0				130.4				136.0			

																			
Capacity		50HP			52HP			54HP			56HP			58HP			60HP		
Model Name (MMY-)	50 Hz	AP5017T8P-SG			AP5217T8P-SG			AP5417T8P-SG			AP5617T8P-SG			AP5817T8P-SG			AP6017T8P-SG		
Units in combination (MMY-)		MAP2007T8P-SG	MAP1607T8P-SG	MAP1407T8P-SG	MAP2007T8P-SG	MAP1807T8P-SG	MAP1407T8P-SG	MAP2007T8P-SG	MAP2007T8P-SG	MAP1407T8P-SG	MAP2007T8P-SG	MAP2007T8P-SG	MAP1607T8P-SG	MAP2007T8P-SG	MAP2007T8P-SG	MAP1807T8P-SG	MAP2007T8P-SG	MAP2007T8P-SG	
Cooling capacity (kW)		141.0			146.4			152.0			157.0			162.4			168.0		

* Power: 3-phase 50 Hz 400V (380 - 415V) / 3-phase 60 Hz 380V
 * The source voltage must not fluctuate more than ±10%.
 * Rated conditions
 Cooling: Indoor air temperature 27°C DB/19°C WB, outdoor air temperature 35°C DB

High efficiency Model

Capacity		14HP	16HP		18HP	20HP		22HP		24HP			
Model Name (MMY-)	50 Hz	MAP14A7T8P-SG	AP1627T8P-SG		AP1827T8P-SG		AP2027T8P-SG		AP2227T8P-SG		AP2427T8P-SG		
Units in combination (MMY-)		-	MAP0807T8P-SG	MAP0807T8P-SG	MAP1007T8P-SG	MAP0807T8P-SG	MAP1007T8P-SG	MAP1007T8P-SG	MAP1207T8P-SG	MAP1007T8P-SG	MAP0807T8P-SG	MAP0807T8P-SG	MAP0807T8P-SG
Cooling capacity (kW)		40.0	44.8		50.4		56.0		61.5		67.2		
Energy Label													

Capacity		26HP		28HP		30HP			32HP		34HP		
Model Name (MMY-)	50 Hz	AP2627T8P-SG		AP2827T8P-SG		AP3027T8P-SG			AP3227T8P-SG		AP3427T8P-SG		
Units in combination (MMY-)		MAP14A7T8P-SG	MAP1207T8P-SG	MAP14A7T8P-SG	MAP14A7T8P-SG	MAP1007T8P-SG	MAP1007T8P-SG	MAP1007T8P-SG	MAP1207T8P-SG	MAP1007T8P-SG	MAP1007T8P-SG	MAP1207T8P-SG	MAP1007T8P-SG
Cooling capacity (kW)		73.5		80.0		84.0			89.5		95.0		

Capacity		36HP			38HP			40HP			42HP		
Model Name (MMY-)	50 Hz	AP3627T8P-SG			AP3827T8P-SG			AP4027T8P-SG			AP4227T8P-SG		
Units in combination (MMY-)		MAP1207T8P-SG	MAP1207T8P-SG	MAP1207T8P-SG	MAP14A7T8P-SG	MAP1207T8P-SG	MAP1207T8P-SG	MAP14A7T8P-SG	MAP14A7T8P-SG	MAP1207T8P-SG	MAP14A7T8P-SG	MAP14A7T8P-SG	MAP14A7T8P-SG
Cooling capacity (kW)		105.0			107.0			113.5			120.0		





Capacity		44HP		46HP		48HP		50HP		52HP		54HP	
Model Name (MMY-)	50 Hz	AP4427T8P-SG		AP4627T8P-SG		AP4827T8P-SG		AP5027T8P-SG		AP5227T8P-SG		AP5427T8P-SG	
Units in combination (MMY-)		MAP1607T8P-SG	MAP14A7T8P-SG	MAP14A7T8P-SG	MAP1807T8P-SG	MAP14A7T8P-SG	MAP14A7T8P-SG	MAP1607T8P-SG	MAP1607T8P-SG	MAP1607T8P-SG	MAP1807T8P-SG	MAP1807T8P-SG	MAP1807T8P-SG
Cooling capacity (kW)		125.0		130.4		135.0		140.4		145.8		151.2	

	Y-shape branching joint				Branch headers				Outdoor unit connection piping kit			
Appearance												
Model name	RBM BY55E-SG	RBM BY105E-SG	RBM BY205E-SG	RBM BY305E-SG	RBM BY1043-SG	RBM BY2043E-SG	RBM BY1083E-SG	RBM BY2083E-SG	RBM-BT14E-SG		RBM-BT24E-SG	
Usage (Classification according to indoor unit capacity code)	Total below 6.4	Total 6.4 or more and below 14.2	Total 14.2 or more and below 25.2	Total 25.2 or more	Max.4 branches		Max.8 branches		Total below 26.0		Total 26.0 or more	
					Total below 14.2	Total 14.2 or more and below 25.2	Total below 14.2	Total 14.2 or more and below 25.2				





× Anti-Corrosion protection model : MMY-MAP****T8JP, MMY-MAP****T7JP

Outdoor unit specifications

Standard model (Single unit)

Equivalent HP			Technical specifications					
			8HP	10HP	12HP	14HP	16HP	
Model name	50Hz (MMY-)		MAP0807T8P-SG	MAP1007T8P-SG	MAP1207T8P-SG	MAP1407T8P-SG	MAP1607T8P-SG	
Energy Label								
Outdoor unit type			Inverter					
Power supply (*1)			3phase 4wires 50Hz 400V (380-415V)/3phase 4 wires 60Hz 380 Hz					
Cooling (*2)	Capacity 100%	(kW)	22.4	28.0	33.5	40.0	45.0	
	Power consumption	(kW)	4.65	6.57	8.38	11.4	12.5	
	EER (Energy Efficiency Ratio)	Capacity 100%		4.82	4.26	4.00	3.50	3.60
		Capacity 80%		5.79	5.31	5.04	4.32	4.32
Capacity 50%			7.27	7.11	6.29	5.78	5.75	
External dimensions (Height / Width / Depth)	(mm)		1,800 / 990 / 780	1,800 / 990 / 780	1,800 / 990 / 780	1,800 / 990 / 780	1,800 / 1,210 / 780	
Total weight	(kg)		200	200	200	200	281	
Compressor	Motor output	(kW)	4.0 x 1	5.8 x 1	7.1 x 1	10.0 x 1	5.5 x 2	
Fan unit	Motor output	(kW)	1.0	1.0	1.0	1.0	1.0	
	Air volume	(m ³ /h)	9,700	9,700	12,200	12,200	12,600	
Refrigerant piping	Main pipe diameter	Gas side	(mm)	ø 19.1	ø 22.2	ø 28.6	ø 28.6	ø 28.6
		Liquid side	(mm)	ø 12.7	ø 12.7	ø 12.7	ø 15.9	ø 15.9
Sound pressure level	(dB(A))		55	57	60	61	61	
Diversity ^{(*)3}			200%	200%	200%	200%	200%	
Max.external static pressure	(Pa)		60	60	50	40	40	
Recommended Isolator	A		20	32	32	32	32	

Standard model (Single unit)

Equivalent HP			Technical specifications				
			18HP	20HP	22HP	24HP	
Model name	50Hz (MMY-)		MAP1807T8P-SG	MAP2007T8P-SG	MAP2207T8P-SG	MAP2407T8P-SG	
Energy Label							
Outdoor unit type			Inverter				
Power supply (*1)			3phase 4wires 50Hz 400V (380-415V) / 3phase 4wires 60Hz 380V				
Cooling (*2)	Capacity 100%	(kW)	50.4	56.0	61.5	67.0	
	Power consumption	(kW)	14.8	17.4	18.6	22.9	
	EER (Energy Efficiency Ratio)	Capacity 100%		3.40	3.22	3.30	2.93
		Capacity 80%		4.15	3.93	4.00	3.67
Capacity 50%			5.82	5.61	5.39	4.75	
External dimensions (Height / Width / Depth)	(mm)		1,800/1,210/780	1,800/1,210/780	1,800/1,600/780	1,800/1,600/780	
Total weight	(kg)		281	281	340	340	
Compressor	Motor output	(kW)	6.6 x 2	7.8 x 2	8.2 x 2	10.3 x 2	
Fan unit	Motor output	(kW)	1.0	1.0	2.0	2.0	
	Air volume	(m ³ /h)	12,600	12,600	18,500	18,500	
Refrigerant piping	Main pipe diameter	Gas side	(mm)	ø 28.6	ø 28.6	ø 28.6	ø 34.9
		Liquid side	(mm)	ø 15.9	ø 15.9	ø 19.1	ø 19.1
Sound pressure level	(dB(A))		61	61	63	63	
Diversity ^{(*)3}			200%	200%	200%	200%	
Max.external static pressure	(Pa)		40	40	40	40	
Recommended Isolator	A		40	63	63	63	

Outdoor unit specifications

Standard model (Combination)

Equivalent HP		26HP		28HP		30HP		
Model name	50Hz (MMY-)	AP2617T8P-SG		AP2817T8P-SG		AP3017T8P-SG		
Outdoor unit type		Inverter						
Power supply (*1)		3phase 4wires 50Hz 400V (380-415V) / 3phase 4wires 60Hz 380V						
Outdoor unit model	50Hz (MMY-)	MAP1407T8P-SG	MAP1207T8P-SG	MAP1407T8P-SG	MAP1407T8P-SG	MAP1607T8P-SG	MAP1407T8P-SG	
Cooling (*2)	Capacity 100%	(kW) 73.5		80.0		85.0		
	Power consumption	(kW) 19.7		22.9		23.9		
	EER (Energy Efficiency Ratio)	Capacity 100%	3.73		3.50		3.55	
		Capacity 80%	4.63		4.32		4.33	
	Capacity 50%	6.00		5.77		5.77		
Total weight	(kg)	200	200	200	200	281	200	
Compressor	Motor output	(kW) 10.0 x 1		7.1 x 1		10.0 x 1		
	Motor output	(kW) 1.0		1.0		1.0		
Fan unit	Air volume	(m ³ /h) 12,200		12,200		12,200		
	Refrigerant piping	Main pipe diameter	Gas side (mm)	ø 34.9		ø 34.9		
		Liquid side (mm)	ø 19.1		ø 19.1			
Sound pressure level	(dB(A))	63.5		64.0		64.0		
Diversity ^(3*)		180%		180%		180%		

Standard model (Combination)

Equivalent HP		32HP		34HP		36HP		
Model name	50Hz (MMY-)	AP3217T8P-SG		AP3417T8P-SG		AP3617T8P-SG		
Outdoor unit type		Inverter						
Power supply (*1)		3phase 4wires 50Hz 400V (380-415V) / 3phase 4wires 60Hz 380V						
Outdoor unit model	50Hz (MMY-)	MAP1607T8P-SG	MAP1607T8P-SG	MAP1807T8P-SG	MAP1607T8P-SG	MAP1807T8P-SG	MAP1807T8P-SG	
Cooling (*2)	Capacity 100%	(kW) 90.0		95.4		100.8		
	Power consumption	(kW) 25.0		27.3		29.6		
	EER (Energy Efficiency Ratio)	Capacity 100%	3.60		3.49		3.40	
		Capacity 80%	4.31		4.24		4.15	
	Capacity 50%	5.76		5.79		5.79		
Total weight	(kg)	281	281	281	281	281	281	
Compressor	Motor output	(kW) 5.5 x 2		5.5 x 2		6.6 x 2		
	Motor output	(kW) 1.0		1.0		1.0		
Fan unit	Air volume	(m ³ /h) 12,600		12,600		12,600		
	Refrigerant piping	Main pipe diameter	Gas side (mm)	ø 34.9		ø 34.9		
		Liquid side (mm)	ø 19.1		ø 19.1			
Sound pressure level	(dB(A))	64.0		64.0		64.0		
Diversity ^(3*)		180%		180%		180%		

*1 The source voltage must not fluctuate more than ±10%.

*2 Rated conditions Cooling : Indoor air temperature 27°C DB/19°C WB, Outdoor air temperature 35°C DB

Based on equivalent piping length of 7.5 m and piping height difference of 0 m.

*3 Be sure to refer to the Engineering Data book for details of those conditions and requirements.

Outdoor unit specifications

Standard model (Combination)

Equivalent HP		38HP			40HP		42HP			
Model name	50Hz (MMY-)	AP3817T8P			AP4017T8P		AP4217T8P			
	60Hz (MMY-)	AP3817T7P			AP4017T7P		AP4217T7P			
Outdoor unit type		Inverter								
Power supply (*1)		3phase 4wires 50Hz 400V (380-415V) / 3phase 4wires 60Hz 380V								
Outdoor unit model	50Hz (MMY-)	MAP2007T8P	MAP1807T8P	MAP2007T8P	MAP2007T8P	MAP1407T8P	MAP1407T8P	MAP1407T8P	MAP1407T8P	
	60Hz (MMY-)	MAP2007T7P	MAP1807T7P	MAP2007T7P	MAP2007T7P	MAP1407T7P	MAP1407T7P	MAP1407T7P	MAP1407T7P	
Cooling (*2)	Capacity 100%	(kW) 106.4			112.0		120.0			
	Power consumption	(kW) 32.1			34.8		34.3			
	EER (Energy Efficiency Ratio)	Capacity 100%	3.31			3.22		3.50		
		Capacity 80%	4.03			3.91		4.32		
Capacity 50%		5.71			5.61		5.77			
Total weight		281	281	281	281	200	200	200		
Compressor	Motor output	(kW) 7.8 x 2	6.6 x 2	7.8 x 2	7.8 x 2	10.0 x 1	10.0 x 1	10.0 x 1		
	Fan unit	Motor output	(kW) 1.0	1.0	1.0	1.0	1.0	1.0	1.0	
Fan unit	Air volume	(m ³ /h) 12,600	12,600	12,600	12,600	12,200	12,200	12,200		
	Refrigerant piping	Main pipe diameter	Gas side (mm)	ø 41.3			ø 41.3		ø 41.3	
Liquid side (mm)		ø 22.2			ø 22.2		ø 22.2			
Sound pressure level		(dB(A)) 64.0	64.0			66.0				
Diversity(*3)		180%			180%		150%			

Standard model (Combination)

Equivalent HP		44HP			46HP			48HP			
Model name	50Hz (MMY-)	AP4417T8P-SG			AP4617T8P-SG			AP4817T8P-SG			
	Outdoor unit type		Inverter								
Power supply (*1)		3phase 4wires 50Hz 400V (380-415V) / 3phase 4wires 60Hz 380V									
Outdoor unit model	50Hz (MMY-)	MAP1607T8P-SG	MAP1407T8P-SG	MAP1407T8P-SG	MAP1807T8P-SG	MAP1407T8P-SG	MAP1407T8P-SG	MAP2007T8P-SG	MAP1407T8P-SG	MAP1407T8P-SG	
	Capacity 100%	(kW) 125.0			130.4			136.0			
Cooling (*2)	Power consumption	(kW) 35.3			37.7			40.2			
	EER (Energy Efficiency Ratio)	Capacity 100%	3.54			3.46			3.38		
		Capacity 80%	4.33			4.26			4.15		
		Capacity 50%	5.79			5.77			5.71		
Total weight	(kg) 281	200	200	281	200	200	281	200	200		
Compressor	Motor output	(kW) 5.5 x 2	10.0 x 1	10.0 x 1	6.6 x 2	10.0 x 1	10.0 x 1	7.8 x 2	10.0 x 1	10.0 x 1	
	Fan unit	Motor output	(kW) 1.0	1.0	1.0	1.0	1.0	1.0	1.0	1.0	
Fan unit	Air volume	(m ³ /h) 12,600	12,200	12,200	12,600	12,200	12,200	12,600	12,200	12,200	
	Refrigerant piping	Main pipe diameter	Gas side (mm)	ø 41.3			ø 41.3		ø 41.3		
Liquid side (mm)		ø 22.2			ø 22.2		ø 22.2				
Sound pressure level		(dB(A)) 66.0	66.0			66.0					
Diversity(*3)		150%			150%			150%			

Standard model (Combination)

Equivalent HP		50HP			52HP			54HP			
Model name	50Hz (MMY-)	AP5017T8P-SG			AP5217T8P-SG			AP5417T8P-SG			
Outdoor unit type	Inverter										
Power supply (*2)	3phase 4wires 50Hz 400V (380-415V) / 3phase 4wires 60Hz 380V										
Outdoor unit model	50Hz (MMY-)	MAP2007T8P-SG	MAP1607T8P	MAP1407T8P	MAP2007T8P	MAP1807T8P	MAP1407T8P	MAP2007T8P	MAP2007T8P	MAP1407T8P	
Cooling (*1)	Capacity 100%	141.0			146.4			152.0			
	Power consumption	41.2			43.6			46.2			
	EER (Energy Efficiency Ratio)	Capacity 100%	3.42			3.36			3.29		
		Capacity 80%	4.15			4.09			4.01		
	Capacity 50%	5.69			5.72			5.67			
Total weight	(kg)	281	281	200	281	281	200	281	281	200	
Compressor	Motor output	7.8 x 2			7.8 x 2			7.8 x 2			
	Motor output	1.0			1.0			1.0			
Fan unit	Air volume	12,600			12,600			12,600			
	Air volume	12,600			12,600			12,600			
Refrigerant piping	Main pipe diameter	ø 41.3			ø 41.3			ø 41.3			
	Main pipe diameter	ø 22.2			ø 22.2			ø 22.2			
Sound pressure level	(dB(A))	66.0			66.0			66.0			
Diversity ^{(*)3}		150%			150%			150%			

Standard model (Combination)

Equivalent HP		56HP			58HP			60HP			
Model name	50Hz (MMY-)	AP5617T8P-SG			AP5817T8P-SG			AP6017T8P-SG			
Outdoor unit type	Inverter										
Power supply (*2)	3phase 4wires 50Hz 400V (380-415V) / 3phase 4wires 60Hz 380V										
Outdoor unit model	50Hz (MMY-)	MAP2007T8P-SG	MAP2007T8P-SG	MAP1607T8P-SG	MAP2007T8P-SG	MAP2007T8P-SG	MAP1807T8P-SG	MAP2007T8P-SG	MAP2007T8P-SG	MAP2007T8P-SG	
Cooling (*1)	Capacity 100%	157.0			162.4			168.0			
	Power consumption	47.1			49.5			52.2			
	EER (Energy Efficiency Ratio)	Capacity 100%	3.33			3.28			3.22		
		Capacity 80%	4.03			3.98			3.92		
	Capacity 50%	5.65			5.68			5.60			
Total weight	(kg)	281	281	281	281	281	281	281	281	281	
Compressor	Motor output	7.8 x 2			7.8 x 2			7.8 x 2			
	Motor output	1.0			1.0			1.0			
Fan unit	Air volume	12,600			12,600			12,600			
	Air volume	12,600			12,600			12,600			
Refrigerant piping	Main pipe diameter	ø 41.3			ø 41.3			ø 41.3			
	Main pipe diameter	ø 22.2			ø 22.2			ø 22.2			
Sound pressure level	(dB(A))	66.0			66.0			66.0			
Diversity ^{(*)3}		150%			150%			150%			

*1 The source voltage must not fluctuate more than ±10%.

*2 Rated conditions Cooling : Indoor air temperature 27°C DB/19°C WB, Outdoor air temperature 35°C DB
Based on equivalent piping length of 7.5 m and piping height difference of 0 m.

*3 Be sure to refer to the Engineering Data book for details of those conditions and requirements.

Outdoor unit specifications

High efficiency model (Single unit/Combination)

Equivalent HP			14HP	16HP	18HP	
Model name	50Hz (MMY-)		MAP14A7T8P-SG	AP1627T8P-SG	AP1827T8P-SG	
Energy Label						
Outdoor unit type	Inverter					
Power supply (*1)	3phase 4wires 50Hz 400V (380-415V) / 3phase 4wires 60Hz 380V					
Outdoor unit model	50Hz (MMY-)		MAP14A7T8P-SG	MAP0807T8P-SG	MAP0807T8P-SG	
Cooling (*2)	Capacity 100%	(kW)	40.0	44.8	50.4	
	Power consumption	(kW)	10.4	9.29	11.2	
	EER (Energy Efficiency Ratio)	Capacity 100%		3.85	4.82	4.51
		Capacity 80%		4.58	5.79	5.51
Capacity 50%			5.92	7.27	7.18	
External dimensions (Height / Width / Depth)	(mm)		1,800 / 1,210 / 780	1,800 / 990 / 780	1,800 / 990 / 780	
Total weight	(kg)		281	200	200	
Compressor	Motor output	(kW)	4.6 x 2	4.0 x 1	4.0 x 1	
Fan unit	Motor output	(kW)	1.0	1.0	1.0	
	Air volume	(m ³ /h)	12,200	9,700	9,700	
Refrigerant piping	Main pipe diameter	Gas side	(mm)	ø 28.6	ø 28.6	
		Liquid side	(mm)	ø 15.9	ø 15.9	
Sound pressure level	(dB(A))		60	58.0	59.5	
Diversity(*3)			200%	180%	180%	
Max. external static pressure	(Pa)		50			

High efficiency model (Combination)

Technical specifications

Equivalent HP			20HP	22HP	24HP	
Model name	50Hz (MMY-)		AP2027T8P-SG	AP2227T8P-SG	AP2427T8P-SG	
Outdoor unit type	Inverter					
Power supply (*1)	3phase 4wires 50Hz 400V (380-415V) / 3phase 4wires 60Hz 380V					
Outdoor unit model	50Hz (MMY-)		MAP1007T8P-SG	MAP1007T8P-SG	MAP1007T8P-SG	
Cooling (*2)	Capacity 100%	(kW)	56.0	61.5	67.2	
	Power consumption	(kW)	13.1	14.9	13.9	
	EER (Energy Efficiency Ratio)	Capacity 100%		4.26	4.12	4.82
		Capacity 80%		5.31	5.16	5.80
Capacity 50%			7.11	6.64	7.27	
External dimensions (Height / Width / Depth)	(mm)		1,800/990/780	1,800/990/780	1,800/990/780	
Total weight	(kg)		200	200	200	
Compressor	Motor output	(kW)	5.8 x 1	5.8 x 1	7.1 x 1	
Fan unit	Motor output	(kW)	1.0	1.0	1.0	
	Air volume	(m ³ /h)	9,700	9,700	12,200	
Refrigerant piping	Main pipe diameter	Gas side	(mm)	ø 28.6	ø 28.6	
		Liquid side	(mm)	ø 15.9	ø 19.1	
Sound pressure level	(dB(A))		60.0	62.0	60.0	
Diversity(*3)			180%	180%	150%	

Outdoor unit specifications

High efficiency model (Combination)

Equivalent HP			26HP		28HP		30HP			
Model name	50Hz (MMY-)		AP2627T8P		AP2827T8P		AP3027T8P			
	60Hz (MMY-)		AP2627T7P		AP2827T7P		AP3027T7P			
Outdoor unit type			Inverter							
Power supply (*1)			3phase 4wires 50Hz 400V (380-415V) / 3phase 4wires 60Hz 380V							
Outdoor unit model	50Hz (MMY-)		MAP14A7T8P	MAP1207T8P	MAP14A7T8P	MAP14A7T8P	MAP1007T8P	MAP1007T8P	MAP1007T8P	
	60Hz (MMY-)		MAP14A7T7P	MAP1207T7P	MAP14A7T7P	MAP14A7T7P	MAP1007T7P	MAP1007T7P	MAP1007T7P	
Cooling (*2)	Capacity 100% (kW)		73.5		80.0		84.0			
	Power consumption (kW)		18.8		20.8		19.7			
	EER (Energy Efficiency Ratio)	Capacity 100%		3.92		3.85		4.26		
		Capacity 80%		4.78		4.57		5.29		
Capacity 50%			6.08		5.93		7.09			
External dimensions (Height / Width / Depth) (mm)			1,800 / 1,210 / 780	1,800 / 990 / 780	1,800 / 1,210 / 780	1,800 / 1,210 / 780	1,800 / 990 / 780	1,800 / 990 / 780	1,800 / 990 / 780	
Total weight (kg)			281	200	281	281	200	200	200	
Compressor	Motor output (kW)		4.6 x 2	7.1 x 1	4.6 x 2	4.6 x 2	5.8 x 1	5.8 x 1	5.8 x 1	
	Motor output (kW)		1.0	1.0	1.0	1.0	1.0	1.0	1.0	
Fan unit	Air volume (m ³ /h)		12,200	12,200	12,200	12,200	9,700	9,700	9,700	
	Refrigerant piping	Main pipe diameter	Gas side (mm)	ø 34.9		ø 34.9		ø 34.9		
		Liquid side (mm)	ø 19.1		ø 19.1		ø 19.1			
Sound pressure level (dB(A))			63.0		63		62.0			
Diversity ^{(*)3}			180%		180%		150%			

High efficiency model (Combination)

Equivalent HP			32HP			34HP			36HP			
Model name	50Hz (MMY-)		AP3227T8P-SG			AP3427T8P-SG			AP3627T8P-SG			
Outdoor unit type			Inverter									
Power supply (*1)			3phase 4wires 50Hz 400V (380-415V) / 3phase 4wires 60Hz 380V									
Outdoor unit model	50Hz (MMY-)		MAP1207T8P-SG	MAP1007T8P-SG	MAP1007T8P-SG	MAP1207T8P-SG	MAP1007T8P-SG	MAP1007T8P-SG	MAP1207T8P-SG	MAP1007T8P-SG	MAP1007T8P-SG	
Cooling (*2)	Capacity 100% (kW)		89.5			95.0			100.5			
	Power consumption (kW)		21.5			23.3			25.1			
	EER (Energy Efficiency Ratio)	Capacity 100%		4.16			4.08			4.00		
		Capacity 80%		5.19			5.10			5.03		
Capacity 50%			6.78			6.50			6.28			
External dimensions (Height / Width / Depth) (mm)			1,800/990/780	1,800/990/780	1,800/990/780	1,800/990/780	1,800/990/780	1,800/990/780	1,800/990/780	1,800/990/780	1,800/990/780	
Total weight (kg)			200	200	200	200	200	200	200	200	200	
Compressor	Motor output (kW)		7.1 x 1	5.8 x 1	5.8 x 1	7.1 x 1	7.1 x 1	5.8 x 1	7.1 x 1	7.1 x 1	7.1 x 1	
	Motor output (kW)		1.0	1.0	1.0	1.0	1.0	1.0	1.0	1.0	1.0	
Fan unit	Air volume (m ³ /h)		12,200	9,700	9,700	12,200	9,700	9,700	12,200	12,200	12,200	
	Refrigerant piping	Main pipe diameter	Gas side (mm)	ø 34.9			ø 34.9			ø 41.3		
		Liquid side (mm)	ø 19.1			ø 19.1			ø 22.2			
Sound pressure level (dB(A))			63.0			64.0			65.0			
Diversity ^{(*)3}			150%			150%			150%			

*1 The source voltage must not fluctuate more than ±10%.

*2 Rated conditions Cooling : Indoor air temperature 27°C DB/19°C WB, Outdoor air temperature 35°C DB

Based on equivalent piping length of 7.5 m and piping height difference of 0 m.

*3 Be sure to refer to the Engineering Data book for details of those conditions and requirements.

Outdoor unit specifications

High efficiency model (Combination)

Equivalent HP			38HP			40HP			42HP		
Model name			AP3827T8P-SG			AP4027T8P-SG			AP4217T8P-SG		
Outdoor unit type			Inverter								
Power supply (*1)			3phase 4wires 50Hz 400V (380-415V) / 3phase 4wires 60Hz 380V								
Outdoor unit model			MAP14A7T8P-SG	MAP1207T8P-SG	MAP1207T8P-SG	MAP14A7T8P-SG	MAP14A7T8P-SG	MAP1207T8P-SG	MAP14A7T8P-SG	MAP14A7T8P-SG	MAP14A7T8P-SG
Cooling (*2)	Capacity 100%		107.0			113.5			120.0		
	Power consumption		27.2			29.1			31.2		
	EER (Energy Efficiency Ratio)	Capacity 100%	3.94			3.90			3.85		
		Capacity 80%	4.86			4.70			4.57		
Capacity 50%		6.14			6.03			5.94			
External dimensions (Height / Width / Depth)			1,800/1,210/780	1,800/990/780	1,800/990/780	1,800/1,210/780	1,800/1,210/780	1,800/990/780	1,800/1,210/780	1,800/1,210/780	1,800/1,210/780
Total weight			281	200	200	281	281	200	281	281	281
Compressor	Motor output		4.6 x 2	7.1 x 1	7.1 x 1	4.6 x 2	4.6 x 2	7.1 x 2	4.6 x 2	4.6 x 2	4.6 x 2
	Air volume		12,200	12,200	12,200	12,200	12,200	12,200	12,200	12,200	12,200
Fan unit	Motor output		1.0	1.0	1.0	1.0	1.0	1.0	1.0	1.0	1.0
	Air volume		12,200	12,200	12,200	12,200	12,200	12,200	12,200	12,200	12,200
Refrigerant piping	Main pipe diameter	Gas side	ø 41.3			ø 41.3			ø 41.3		
		Liquid side	ø 22.2			ø 22.2			ø 22.2		
Sound pressure level			65.0			65.0			65.0		
Diversity ^{(*)3}			150%			150%			150%		

High efficiency model (Combination)

Equivalent HP			44HP			46HP			48HP		
Model name			AP4427T8P-SG			AP4627T8P-SG			AP4827T8P-SG		
Outdoor unit type			Inverter								
Power supply (*1)			3phase 4wires 50Hz 400V (380-415V) / 3phase 4wires 60Hz 380V								
Outdoor unit model			MAP1607T8P-SG	MAP14A7T8P-SG	MAP14A7T8P-SG	MAP1807T8P-SG	MAP14A7T8P-SG	MAP14A7T8P-SG	MAP1607T8P-SG	MAP1607T8P-SG	MAP1607T8P-SG
Cooling (*2)	Capacity 100%		125.0			130.4			135.0		
	Power consumption		33.2			35.5			37.5		
	EER (Energy Efficiency Ratio)	Capacity 100%	3.76			3.67			3.60		
		Capacity 80%	4.48			4.40			4.32		
Capacity 50%		5.84			5.87			5.77			
External dimensions (Height / Width / Depth)			1,800/1,210/780	1,800/1,210/780	1,800/1,210/780	1,800/1,210/780	1,800/1,210/780	1,800/1,210/780	1,800/1,210/780	1,800/1,210/780	1,800/1,210/780
Total weight			281	281	281	281	281	281	281	281	281
Compressor	Motor output		5.5 x 2	4.6 x 2	4.6 x 2	6.6 x 2	4.6 x 2	4.6 x 2	5.5 x 2	5.5 x 2	5.5 x 2
	Air volume		12,600	12,200	12,200	12,600	12,200	12,200	12,600	12,600	12,600
Fan unit	Motor output		1.0	1.0	1.0	1.0	1.0	1.0	1.0	1.0	1.0
	Air volume		12,600	12,200	12,200	12,600	12,200	12,200	12,600	12,600	12,600
Refrigerant piping	Main pipe diameter	Gas side	ø 41.3			ø 41.3			ø 41.3		
		Liquid side	ø 22.2			ø 22.2			ø 22.2		
Sound pressure level			65.5			65.5			66.0		
Diversity ^{(*)3}			150%			150%			150%		

Outdoor unit specifications

High efficiency model (Combination)

Equivalent HP		50HP			52HP			54HP			
Model name	50Hz (MMY-)	AP5027T8P-SG			AP5227T8P-SG			AP5427T8P-SG			
Outdoor unit type		Inverter									
Power supply (*1)		3phase 4wires 50Hz 400V (380-415V) / 3phase 4wires 60Hz 380V									
Outdoor unit model	50Hz (MMY-)	MAP1807T8P-SG	MAP1607T8P-SG	MAP1607T8P-SG	MAP1807T8P-SG	MAP1807T8P-SG	MAP1607T8P-SG	MAP1807T8P-SG	MAP1807T8P-SG	MAP1807T8P-SG	
Cooling (*2)	Capacity 100%	(kW)			140.4			145.8			151.2
	Power consumption	(kW)			39.8			42.1			44.5
	EER (Energy Efficiency Ratio)	Capacity 100%	3.53			3.46			3.40		
		Capacity 80%	4.25			4.19			4.16		
Capacity 50%		5.80			5.79			5.82			
External dimensions (Height / Width / Depth)	(mm)	1,800/1,210/780	1,800/1,210/780	1,800/1,210/780	1,800/1,210/780	1,800/1,210/780	1,800/1,210/780	1,800/1,210/780	1,800/1,210/780	1,800/1,210/780	
Total weight	(kg)	281	281	281	281	281	281	281	281	281	
Compressor	Motor output	(kW)	6.6 x 2	5.5 x 2	5.5 x 2	6.6x 2	6.6 x 2	5.5 x 2	6.6 x 2	6.6 x 2	
Fan unit	Motor output	(kW)	1.0	1.0	1.0	1.0	1.0	1.0	1.0	1.0	
	Air volume	(m ³ /h)	12,600	12,600	12,600	12,600	12,600	12,600	12,600	12,600	
Refrigerant piping	Main pipe diameter	Gas side	(mm)			ø 41.3			ø 41.3		
		Liquid side	(mm)			ø 22.2			ø 22.2		
Sound pressure level		(dB(A))	66.0			66.0			66.0		
Diversity(*3)			150%			150%			150%		

*1 The source voltage must not fluctuate more than ±10%.

*2 Rated conditions Cooling : Indoor air temperature 27°C DB/19°C WB, Outdoor air temperature 35°C DB

Based on equivalent piping length of 7.5 m and piping height difference of 0 m.

*3 Be sure to refer to the Engineering Data book for details of those conditions and requirements.

Outdoor units external drawings

**Model : MMY-MAP0807T7P-SG, MMY-MAP0807T8P
 MMY-MAP1007T7P-SG, MMY-MAP1007T8P
 MMY-MAP1207T7P-SG, MMY-MAP1207T8P
 MMY-MAP1407T7P-SG, MMY-MAP1407T8P**

Model Name	øA	Model Name	øB
MAP0807 type	ø19.1	MAP0807 type	ø12.7
MAP1007 type	ø22.2	MAP1007 type	ø12.7
MAP1207 type	ø28.6	MAP1207 type	ø12.7
MAP1407 type	ø28.6	MAP1407 type	ø15.9

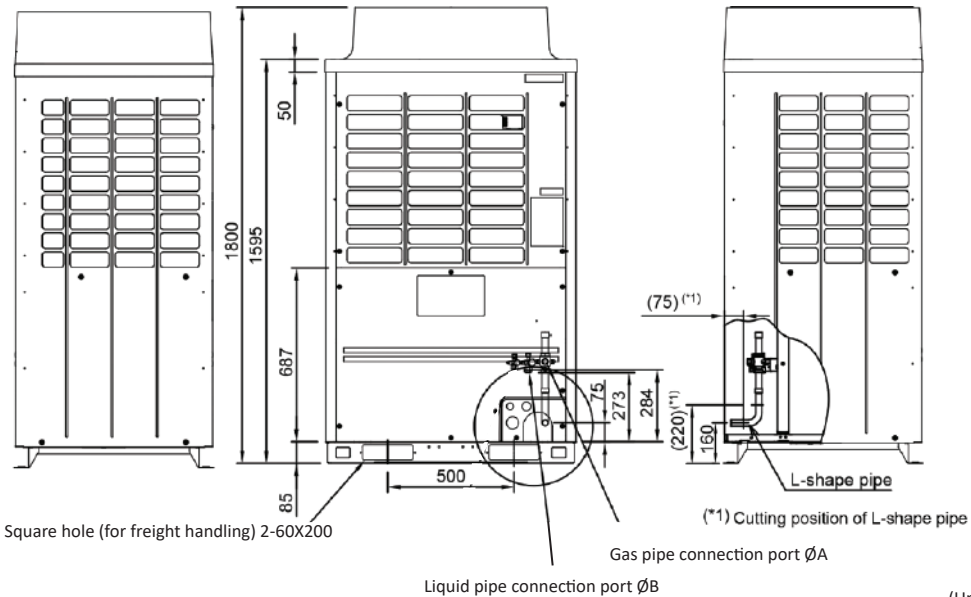
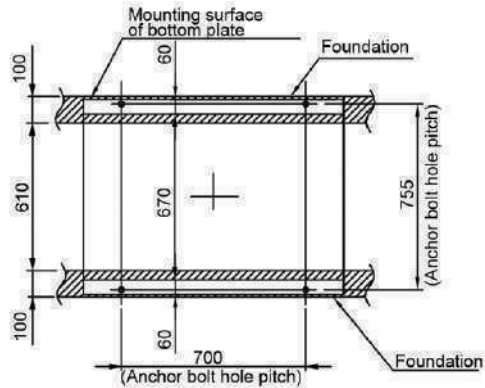
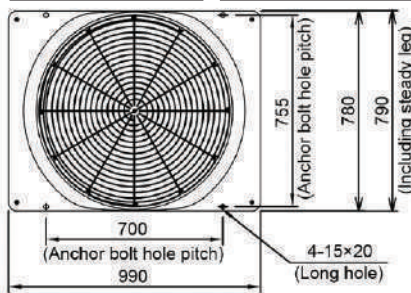

(Note)

1. IF there is an obstacle at the upper side of the outdoor unit, set the top end of the outdoor unit 2000mm apart from the obstacle
2. Limit the height of the obstacle surrounding the outdoor unit to 800mm or less from the bottom end of the outdoor unit.
3. Draw out the pipe procured locally to the front of the outdoor unit horizontally and keep 500mm or more between the outdoor unit and traversing pipe if placing pipe transversely.
4. Dimensional drawing of corrosion heavy protection model is the same as that of standard model.

(Unit:mm)

**Model : MMY-MAP14A7T8P-SG, MMY-MAP14A7T7P
 MMY-MAP1607T8P-SG, MMY-MAP1607T7P
 MMY-MAP1807T8P-SG, MMY-MAP1807T7P
 MMY-MAP2007T8P-SG, MMY-MAP2007T7P**

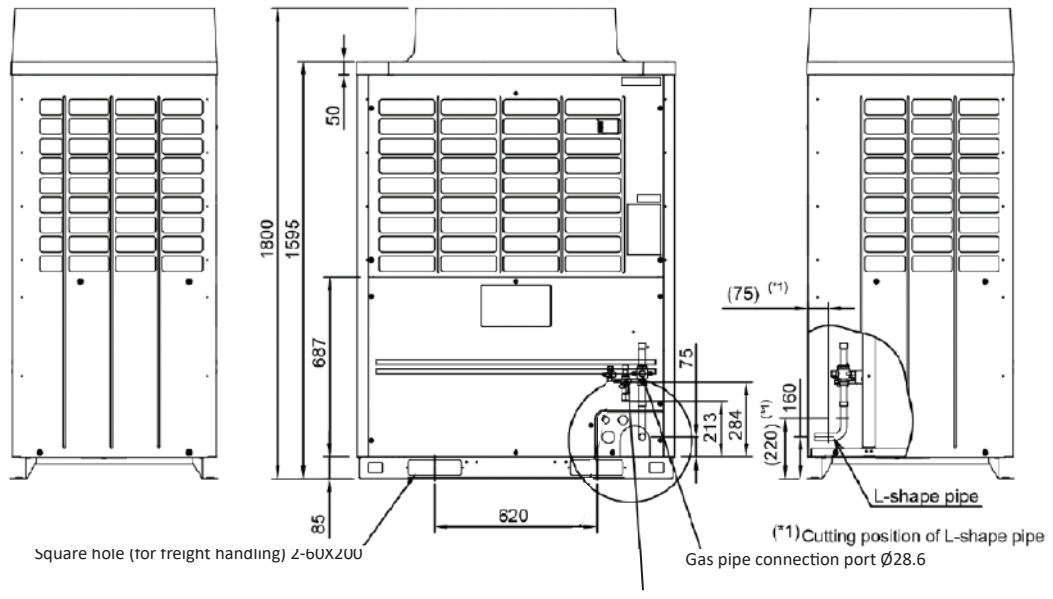
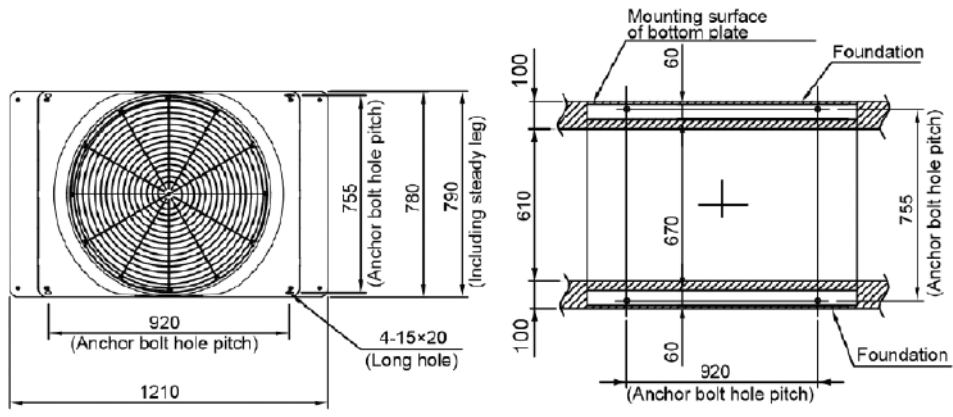

(Note)

1. IF there is an obstacle at the upper side of the outdoor unit, set the top end of the outdoor unit 2000mm apart from the obstacle
2. Limit the height of the obstacle surrounding the outdoor unit to 800mm or less from the bottom end of the outdoor unit.
3. Draw out the pipe procured locally to the front of the outdoor unit horizontally and keep 500mm or more between the outdoor unit and traversing pipe if placing pipe transversely.
4. Dimensional drawing of corrosion heavy protection model is the same as that of standard model.

Liquid pipe connection port Ø15.9

(Unit:mm)

Model : MMY-MAP2207T8P-SG, MMY-MAP2207T7P MMY-MAP2407T8P-SG, MMY-MAP2407T7P

Model Name	ØA
MMY-MAP2207T8P	Ø28.6
MMY-MAP2407T8P	Ø34.9

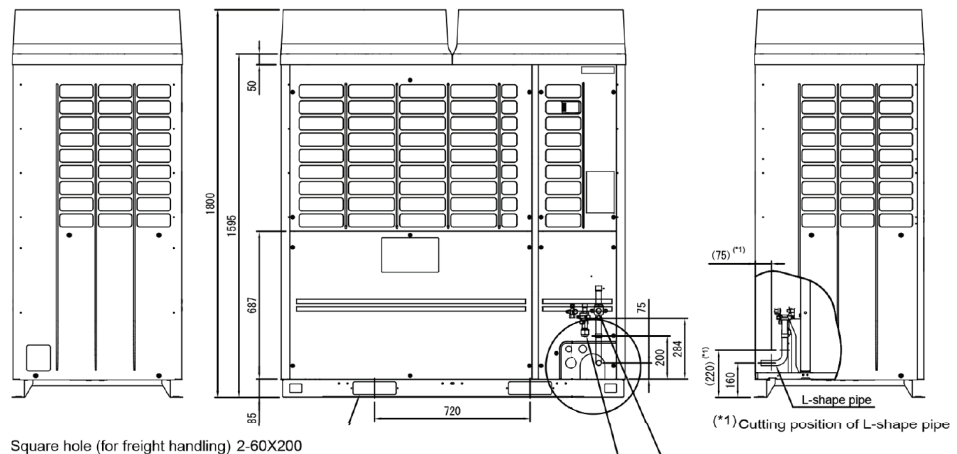
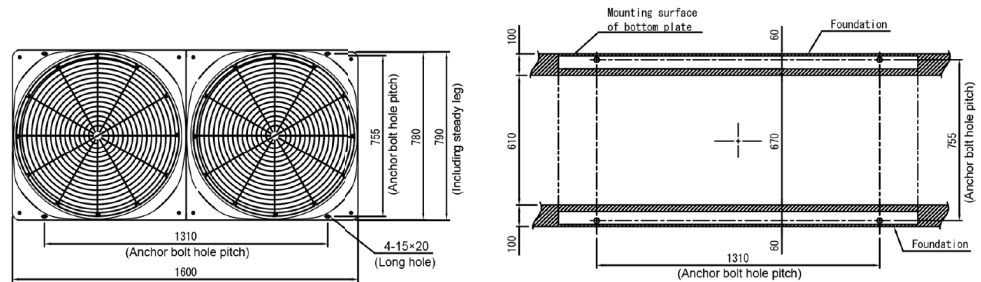

Square hole (for freight handling) 2-60X20

(*1) Cutting position of L-shape pipe

Gas pipe connection port ϕ_A

Liquid pipe connection port 19.1

(Note)

1. If there is an obstacle at the upper side of the outdoor unit, set the top end of the outdoor unit 2000mm apart from the obstacle.
2. Limit the height of the obstacle surrounding the outdoor unit to 800mm or less from the bottom end of the outdoor unit.
3. Draw out the pipe procured locally to the front of the outdoor unit horizontally, and keep 500mm or more between the outdoor unit and traversing pipe if placing pipe transversely.
4. Dimensional drawing of corrosion heavy protection model is the same as that of standard model.

(Unit:mm)



Indoor units

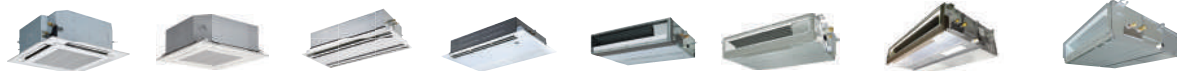

Cooling capacity (HP)	4-way air discharge cassette type (MMU-)	Compact 4-way cassette type (MMU-)	2-way air discharge cassette type (MMU-)	1-way air discharge cassette type (MMU-)	Slim duct type (MMD-)	Super Slim duct type (MMD-)	Concealed duct high static pressure type (MMD-)	Concealed duct type (MMD-)
2.2 kW (0.8 HP)		AP0077MH-E	AP0072WH1	AP0074YH1-E	AP0074SPH1-E	AP0076M(P)HY*		AP0076BHP1-E
2.5 kW (0.9HP)						AP0086M(P)HY*		
2.8 kW (1.0 HP)	AP0094HP1-E	AP0097MH-E	AP0092WH1	AP0094YH1-E	AP0094SPH1-E	AP0096M(P)HY*		AP0096BHP1-E
3.2kW (1.1HP)						AP0106M(P)HY*		
3.6 kW (1.25HP)	AP0124HP1-E	AP0127MH-E	AP0122WH1	AP0124YH1-E	AP0124SPH1-E	AP0126M(P)HY*		AP0126BHP1-E
4.0 kW (1.5HP)						AP0146M(P)HY*		
4.5 kW (1.7 HP)	AP0154HP1-E	AP0157MH-E	AP0152WH1	AP0154SH1-E	AP0154SPH1-E	AP0156M(P)HY*		AP0156BHP1-E
5.0 kW (1.85HP)						AP0176M(P)HY*		
5.6 kW (2.0 HP)	AP0184HP1-E	AP0187MH-E	AP0182WH1	AP0184SH1-E	AP0184SPH1-E	AP0186M(P)HY*	AP0186HP1-E	AP0186BHP1-E
6.3 kW (2.25HP)						AP0206M(P)HY*		
7.1 kW (2.5HP)	AP0244HP1-E		AP0242WH1	AP0244SH1-E	AP0244SPH1-E	AP0246M(P)HY*	AP0246HP1-E	AP0246BHP1-E
8.0 kW (3.0 HP)	AP0274HP1-E		AP0272WH1		AP0274SPH1-E	AP0276M(P)HY*	AP0276HP1-E	AP0276BHP1-E
9.0 kW (3.2 HP)	AP0304HP1-E		AP0302WH1					AP0306BHP1-E
11.2 kW (4.0 HP)	AP0364HP1-E		AP0362WH1				AP0366HP1-E	AP0366BHP1-E
14.0 kW (5.0 HP)	AP0484HP1-E		AP0482WH1				AP0486HP1-E	AP0486BHP1-E
16.0 kW (6.0 HP)	AP0564HP1-E		AP0562WH1				AP0566HP1-E	AP0566BHP1-E
22.4 kW (8.0 HP)							AP0726HP-E	
28.0 kW (10.0 HP)							AP0966HP-E	



Cooling capacity (HP)	Ceiling type (MMC-)	High wall type Series 7 (MMK-)	Floor standing concealed type (MML-)	Floor standing cabinet type (MML-)	Console type (MML-)	Floor standing type (MMF-)	Large capacity floor standing Direct type (MMF-)	Large capacity floor standing Duct type (MMF-)
2.2 kW (0.8 HP)		AP0077HP-E	AP0074BH1-E	AP0074H1-E	AP0074NH1-E			
2.8 kW (1.0 HP)		AP0097HP-E	AP0094BH1-E	AP0094H1-E	AP0094NH1-E			
3.6 kW (1.25 HP)		AP0127HP-E	AP0124BH1-E	AP0124H1-E	AP0124NH1-E			
4.5 kW (1.7 HP)	AP0158HP-E	AP0157HP-E	AP0154BH1-E	AP0154H1-E	AP0154NH1-E	AP0156H1-E		
5.6 kW (2.0 HP)	AP0188HP-E	AP0187HP-E	AP0184BH1-E	AP0184H1-E	AP0184NH1-E	AP0186H1-E		
7.1 kW (2.5 HP)	AP0248HP-E	AP0247HP-E	AP0244BH1-E	AP0244H1-E		AP0246H1-E		
8.0 kW (3.0 HP)	AP0278HP-E					AP0276H1-E		
11.2 kW (4.0 HP)	AP0368HP-E					AP0366H1-E		
14.0 kW (5.0 HP)	AP0488HP-E					AP0486H1-E		
16.0 kW (6.0 HP)	AP0568HP-E					AP0566H1-E		
22.4 kW (8.0 HP)							AP0724H-VA/VB	AP0724DH-V
28.0 kW (10.0 HP)							AP0964H-VA/VB	AP0964DH-V
45.0 kW (16.0 HP)							AP1444H-VA/VB	AP1444DH-V
56.0 kW (20.0 HP)							AP1924H-VA/VB	AP1924DH-V

*Super slim duct MMD-AP***6MPHY, P means coming with drain pump.



Air volume	Fresh air intake indoor unit type (MMD-)	Air to air heat exchanger with DX coil (MMD-)	Air to air heat exchanger**
150 m ³ /h			VN-M150HE
250 m ³ /h			VN-M250HE
350 m ³ /h			VN-M350HE
500 m ³ /h		VN502HEX1E	VN-M500HE
650 m ³ /h			VN-M650HE
800 m ³ /h		VN802HEX1E	VN-M800HE
1000 m ³ /h		VN1002HEX1E / HEX1E2*	VN-M1000HE
1500 m ³ /h			VN-M1500HE
2000 m ³ /h			VN-M2000HE
1080 m ³ /h	AP0481HFE		
1680 m ³ /h	AP0721HFE		
2100 m ³ /h	AP0961HFE		

* 60Hz (7P) Models Only

** Do not connect to refrigerant piping from outdoor unit. Control wires can be connected.



4-way air discharge cassette type

MMU-AP***4HP1-E



Individual louver control

The angles of each of the four louver can be set individually
=> Enables airflow to be adapted to user preferences.

Easy installation

The panel is attached using the bolt already installed on the indoor unit.

(1) Standard swing



(2) Diagonally opposite swing



(3) Turn-around swing

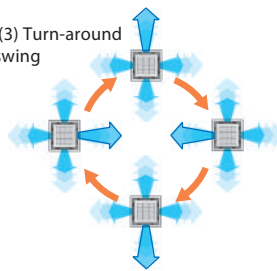

Note: RBC-AMT32E, RBC-AMS41E only



RBC-U31PGP(W)-E

Technical specifications

Model name		MMU-	AP0094HP1-E	AP0124HP1-E	AP0154HP1-E	AP0184HP1-E	AP0244HP1-E	AP0274HP1-E	AP0304HP1-E	AP0364HP1-E	AP0484HP1-E	AP0564HP1-E	
Cooling capacity* ¹		(kW)	2.8	3.6	4.5	5.6	7.1	8.0	9.0	11.2	14.0	16.0	
Electrical characteristics	Power requirements	1-phase 50Hz 230V (220-240V) / 1-phase 60Hz 220V (Separate power supply for indoor units required.)											
	Power consumption 50 Hz/60 Hz (kW)		0.021/0.021	0.023/0.023	0.026/0.026	0.036/0.036	0.043/0.043	0.088/0.088	0.112/0.112	0.112/0.112			
Appearance (Ceiling panel)		Model	RBC-U31PGP(W)-E										
External dimensions: Main unit (Ceiling panel)*	Height (mm)		256 (30)*						319 (30)*				
	Width (mm)		840 (950)*										
	Depth (mm)		840 (950)*										
Total weight: Main unit (Ceiling panel)*		(kg)	18 (4)*			20 (4)*				25 (4)*			
Fan unit	Standard air flow (High/Mid/Low) (m ³ /h)		800/730/680		930/830/790	1050/920/800	1290/920/800		1320/1110/850	1970/1430/1070	2130/1430/1130	2130/1520/1230	
	Motor output (W)		14				20			68	72		
Connecting pipe	Gas side (mm)		ø9.5		ø12.7		ø15.9						
	Liquid side (mm)		ø6.4				ø9.5						
	Drain port (nominal dia.) (mm)		25 (Polyvinyl chloride tube)										
Sound pressure level* ² (High/Mid/Low)		(dB(A))	30/29/27		31/29/27	32/29/27	35/31/28		38/33/30	43/38/32	46/38/33	46/40/33	

* Figures in parentheses are for ceiling panels.

Note 1 : The capacities are measured under the conditions specified by JIS B 8615 based on the reference piping.

The reference piping consists of 5 m of main piping and 2.5 m of branch piping connected with 0 m height.

Note 2 : The sound level are measured in an anechoic chamber in accordance with JIS B 8616.

Normally, the values measured in the actual operating environment become larger than the indicated values due to the effects of external sound.

Note : Rated conditions Cooling : Indoor air temperature 27°C DB/19°C WB, Outdoor air temperature 35°C DB

MMU-AP0074HP1-E to AP0564HP1-E

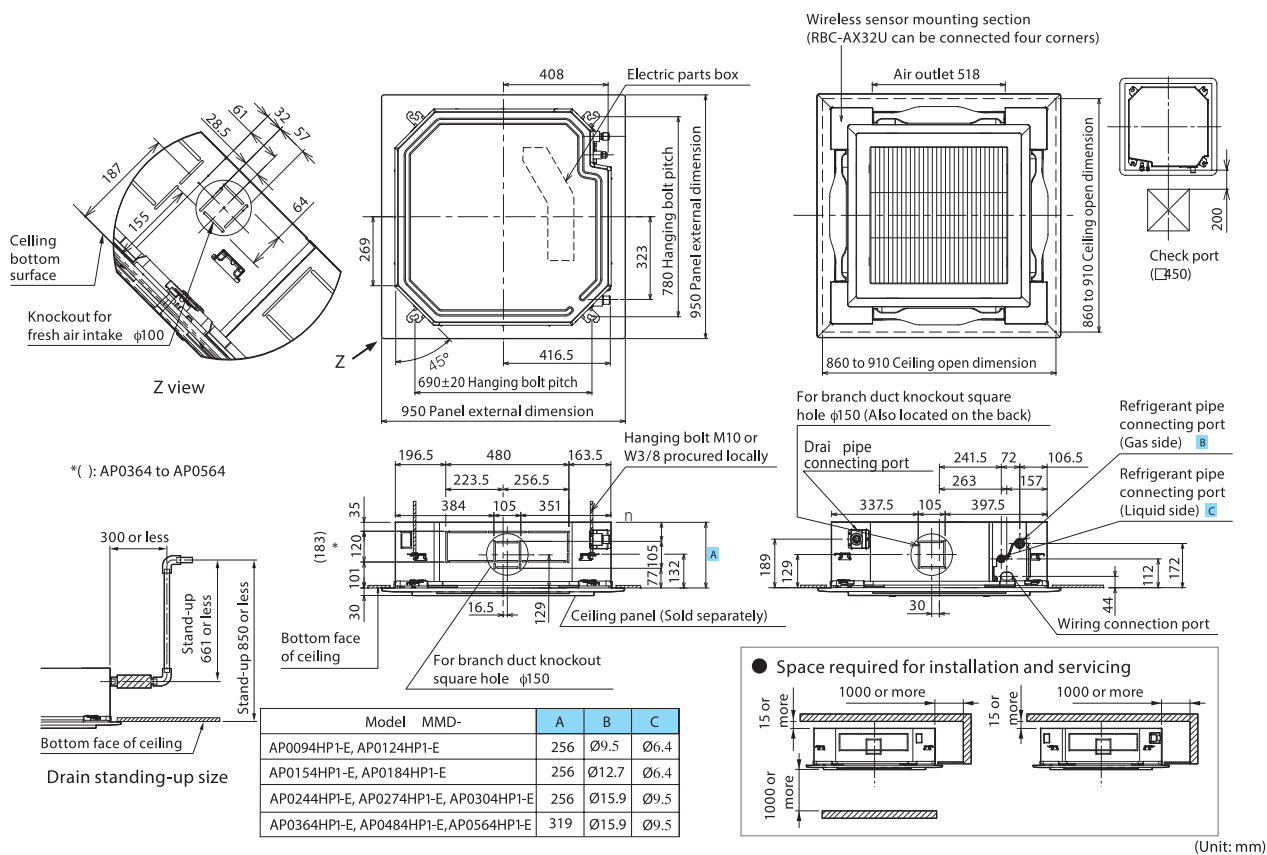

* The figure shows the RBC-U31PGP(W)-E panel.

Options

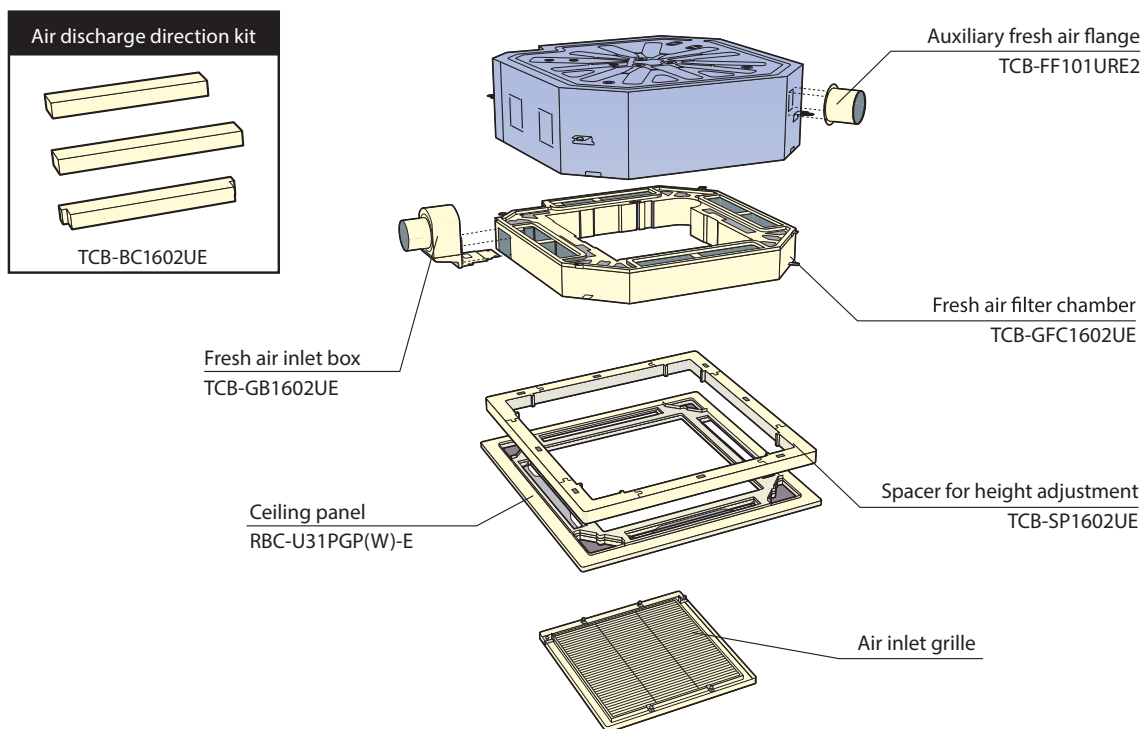

Compact 4-way cassette type

MMU-AP*7MH-E**



Superior design with compact chassis

This compact unit (620 × 620 mm) fits with flat panel perfectly into ceilings and matches standard architectural modules without the need to cut ceiling tiles, makes your room look more elegant.

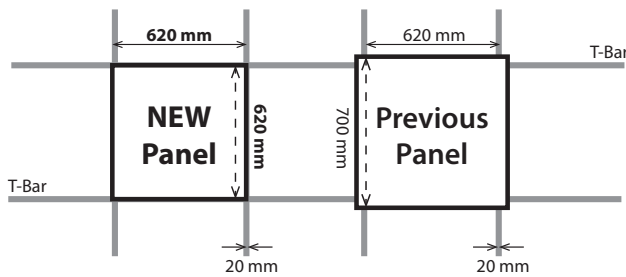

Individual louver control*

The wind direction and swing operation can be set individually by each louver, which can be set into memory for future use. Furthermore, the optional occupancy sensor also improve efficiency energy.

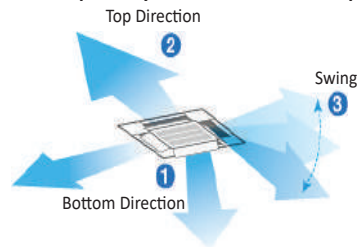

Occupancy sensor



TCB-SJR41UM-E

*The function is available with RBC-AMS55E-ES/EN

Technical specifications

Model name	MMU-	AP0077MH-E	AP0097MH-E	AP0127MH-E	AP0157MH-E	AP0187MH-E	
Cooling capacity*1	(kW)	2.2	2.8	3.6	4.5	5.6	
Electrical characteristics	Power requirements	1-phase 50Hz 230V (220–240V) / 1-phase 60Hz 220V (Separate power supply for indoor units required.)					
	Power consumption 50 Hz/60 Hz	(kW)	0.016/0.016	0.025/0.025	0.027/0.027	0.030/0.030	0.052/0.052
Appearance (Ceiling panel)	Model	RBC-UM21PG(W)-E					
External dimensions: Main unit (Ceiling panel)*	Height	(mm)	256 (12)*				
	Width	(mm)	575 (620)*				
	Depth	(mm)	575 (620)*				
Total weight: Main unit (Ceiling panel)*	(kg)	15 (2.5)*					
Fan unit	Standard air flow (M+ / M / L+ / L)	(m³/h)	552 (500/462/395/378)	570 (520/468/395/378)	594 (550/504/420/402)	660 (600/552/480/468)	840 (740/642/540/522)
	Motor output	(W)	60				
Connecting pipe	Gas side	(mm)	ø9.5		ø12.7		
	Liquid side	(mm)	ø6.4				
	Drain port (Nominal dia. mm)		VP 20 (Polyvinyl chloride tube)				
Sound pressure level*2 High (M+ / M / L+ / L)	(dB(A))	37 (34/33/30/29)	38 (35/33/30/29)	38 (36/34/31/30)	40 (37/35/32/31)	47 (43/39/36/34)	

* Figures in parentheses are for ceiling panels.

Note 1 : The capacities are measured under the conditions specified by JIS B 8615 based on the reference piping.

The reference piping consists of 5 m of main piping and 2.5 m of branch piping connected with 0 m height.

Note 2 : The sound level are measured in an anechoic chamber in accordance with JIS B 8616.

Normally, the values measured in the actual operating environment become larger than the indicated values due to the effects of external sound.

Note : Rated conditions Cooling : Indoor air temperature 27°C DB/19°C WB, Outdoor air temperature 35°C DB

Heating : Indoor air temperature 20°C DB, Outdoor air temperature 7°C DB/6°C WB

Note: M+, L+ will be available with RBC-AMS54E-ES/EN only.

MMU-AP0077MH-E to AP0187MH-E

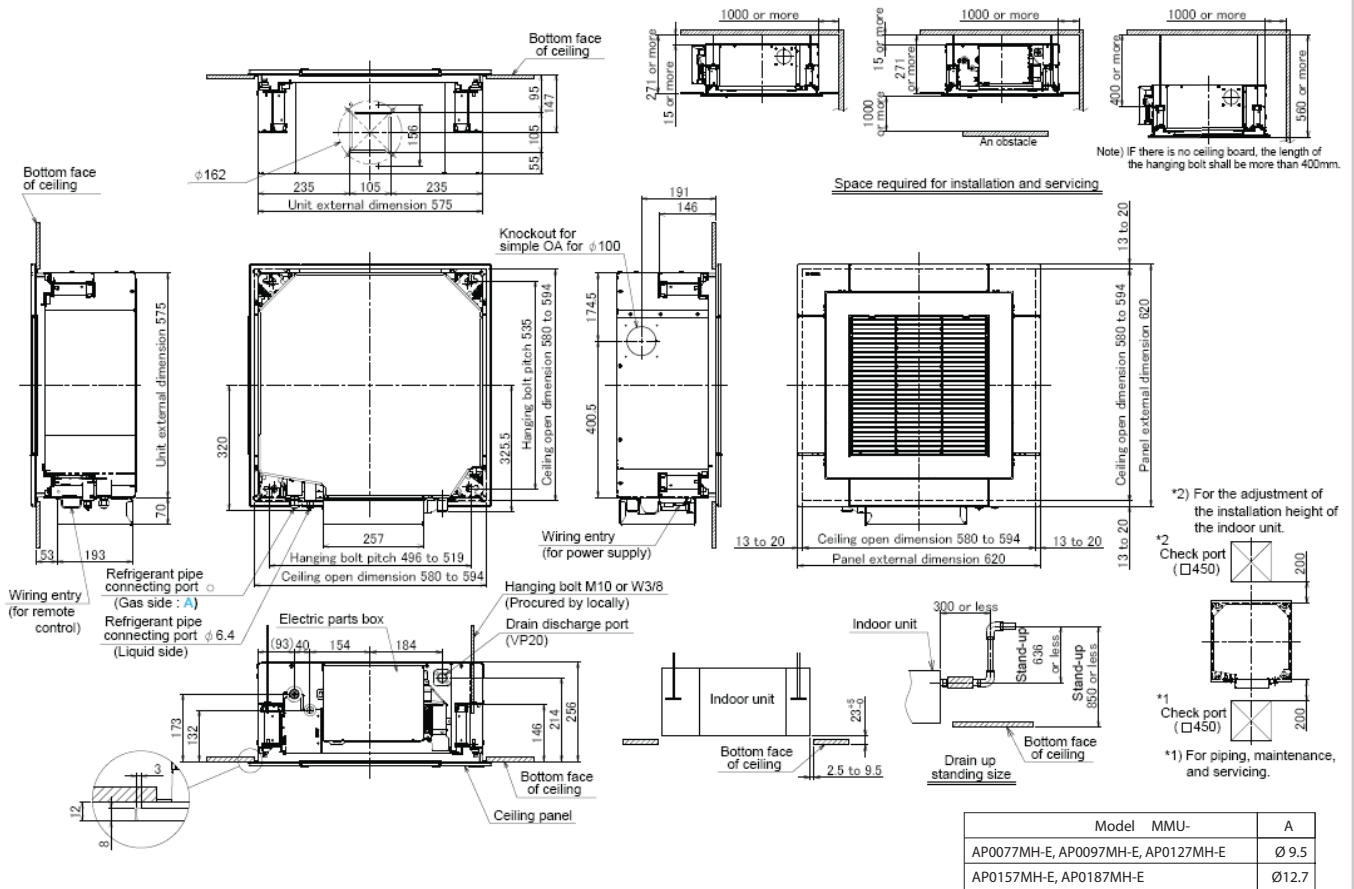

Options

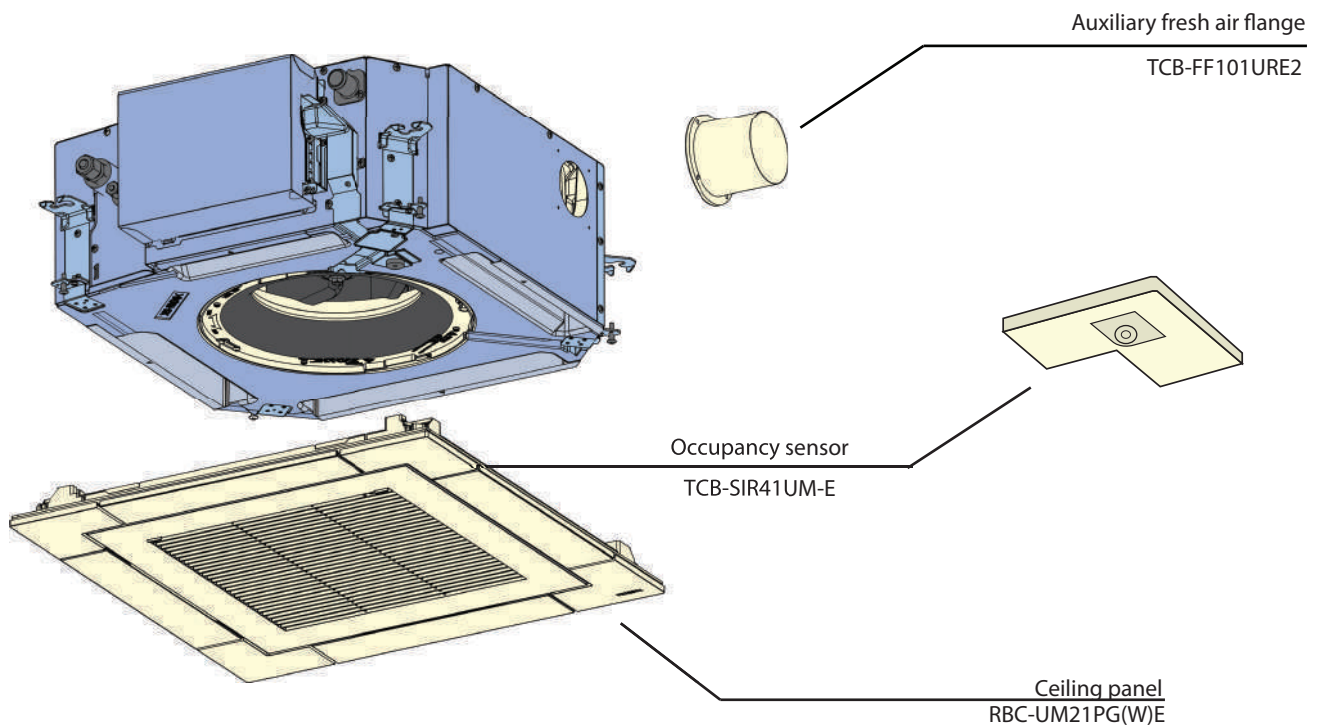

2-way air discharge cassette type

MMU-AP*2WH1**



◀ Slim and compact unit

Unified the width of ceiling panel to 680mm.
 Condensate drain pump included.
 Available for ceilings up to 3.8m in height. (in case of 0.8HP to 3.2HP)
 Easy installation and fine adjustment using the “Adjust-Cover” function.

Technical specifications

Model name		MMU-	AP0072WH1	AP0092WH1	AP0122WH1	AP0152WH1	AP0182WH1	AP0242WH1	AP0272WH1	AP0302WH1	AP0362WH1	AP0482WH1	AP0562WH1						
Cooling capacity*1		(kW)	2.2	2.8	3.6	4.5	5.6	7.1	8.0	9.0	11.2	14.0	16.0						
Electrical characteristics	Power requirements	1-phase 50Hz 230V (220–240V) / 1-phase 60Hz 220V (Separate power supply for indoor units required.)																	
	Power consumption 50 Hz/60 Hz	(kW)	0.029/0.029			0.030/0.030		0.044/0.044		0.054/0.054		0.064/0.064		0.076/0.076		0.088/0.088		0.117/0.117	
Appearance (Ceiling panel)		Model	RBC-UW283PG(W)-E				RBC-UW803PG(W)-E				RBC-UW1403(W)PG-E								
External dimensions: Main unit (Ceiling panel)*	Height	(mm)	295 (20)				345 (20)												
	Width	(mm)	815 (1050)				1180 (1415)				1600 (1835)								
	Depth	(mm)	570 (680)																
Total weight: Main unit (Ceiling panel)*		(kg)	19 (10)				26 (14)				36 (14)								
Fan unit	Standard air flow (High/Mid/Low)	(m³/h)	558/498/450			600/534/450		900/750/618		1050/840/738		1260/900/780		1740/1434/1182		1800/1482/1230		2040/1578/1320	
	Motor output	(W)	20				30		40		50		70						
Connecting pipe	Gas side	(mm)	ø9.5			ø12.7			ø15.9										
	Liquid side	(mm)	ø6.4						ø9.5										
	Drain port	(nominal dia.)	25 (Polyvinyl chloride tube)																
Sound pressure level*2 (High/Mid/Low)		(dB(A))	34/32/30			35/33/30		38/35/33		40/37/34		42/39/36		43/40/37		46/42/39			

* Figures in parentheses are for ceiling panels.

Note 1 : The capacities are measured under the conditions specified by JIS B 8615 based on the reference piping.
 The reference piping consists of 5 m of main piping and 2.5 m of branch piping connected with 0 m height.

Note 2 : The sound level are measured in an anechoic chamber in accordance with JIS B 8616.

Normally, the values measured in the actual operating environment become larger than the indicated values due to the effects of external sound.

Note : Rated conditions Cooling : Indoor air temperature 27°C DB/19°C WB, Outdoor air temperature 35°C DB

MMU-AP0072WH1 to AP0152WH1

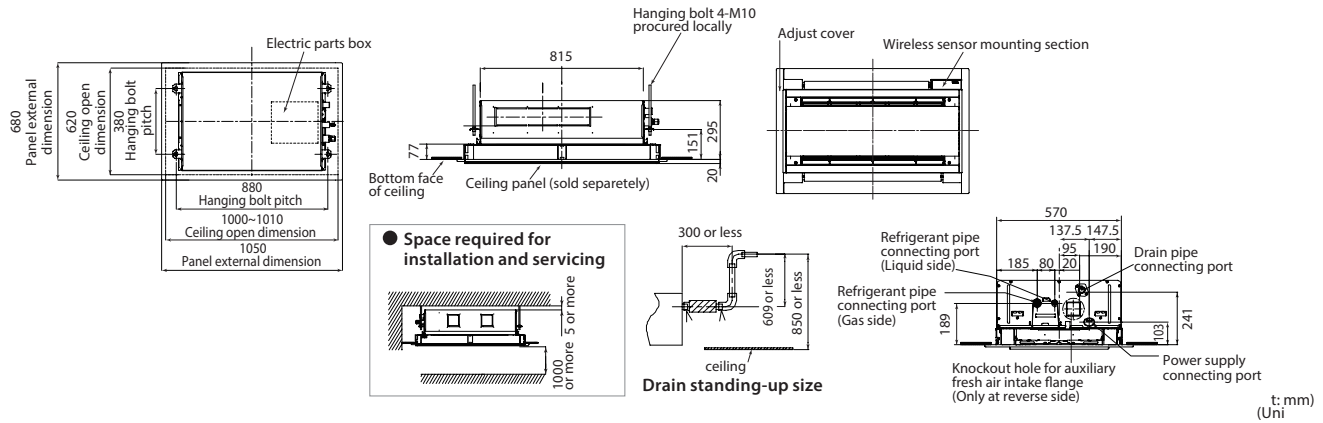

MMU-AP0182WH1 to AP0302WH1

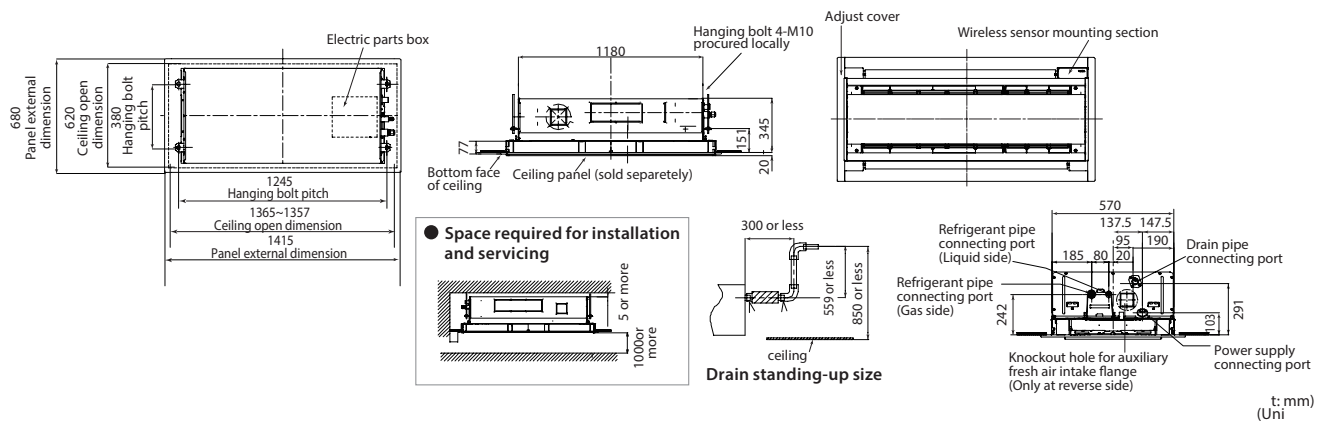

MMU-AP0362WH1 to AP0562WH1

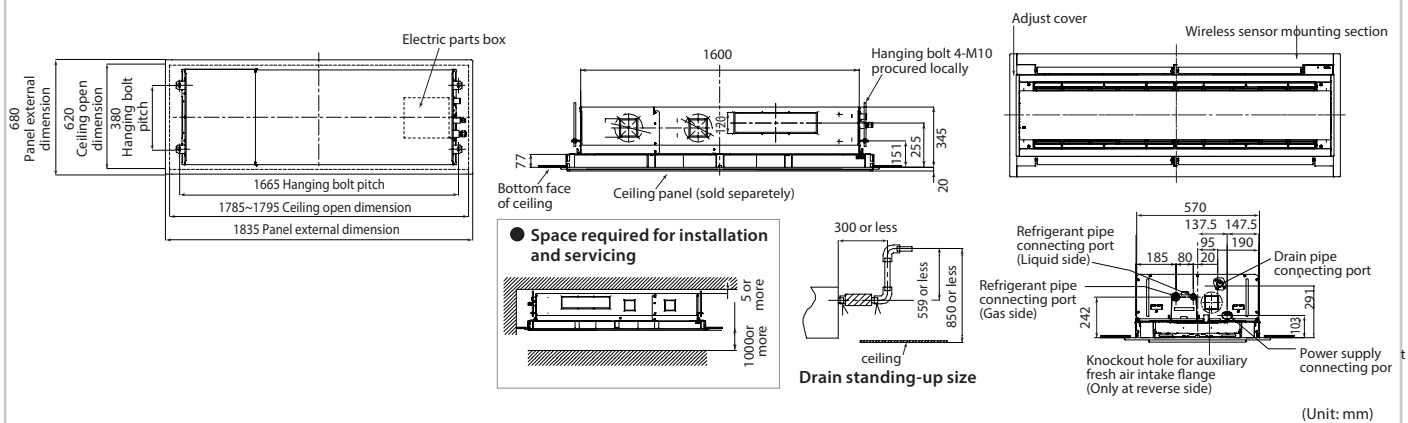

Options

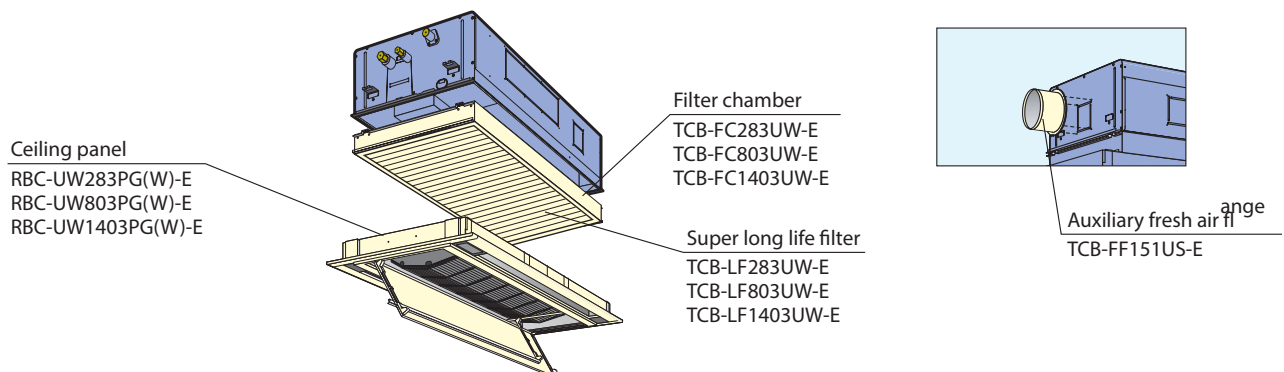

1-way air discharge cassette type

MMU-AP***4YH1-E
MMU-AP***4SH1-E



The perfect choice for hotels and reception areas

Silent sound design ensures the quiet required for the office. Ideal for smaller rooms where one-way air distribution is required. Able to blow air straight out. Condensate drain pump included. Long-life filters fitted as standard.

Fresh air intake is possible (MMU-AP***4SH1-E)

Preparations/connection possible with a circle duct flange.

Technical specifications

Model name	MMU-	AP0074YH1-E	AP0094YH1-E	AP0124YH1-E	AP0154SH1-E	AP0184SH1-E	AP0244SH1-E
Cooling capacity*1	(kW)	2.2	2.8	3.6	4.5	5.6	7.1
Electrical characteristics	Power requirements	1-phase 50Hz 230V (220–240V) / 1-phase 60Hz 220V (Separate power supply for indoor units required.)					
	Power consumption 50 Hz/60 Hz (kW)	0.053/0.056		0.042/0.041		0.046/0.045	
Appearance (Ceiling panel)	Model	RBC-UY136PG			RBC-US21PGE		
External dimensions: Main unit (Ceiling panel)*	Height (mm)	235 (18)*			200 (20)*		
	Width (mm)	850 (1050)*			1000 (1230)*		
	Depth (mm)	400 (470)*			710 (800)*		
Total weight: Main unit (Ceiling panel)*	(kg)	22 (3.5)*			21 (5.5)*		22 (5.5)*
Fan unit	Standard air flow (High/Mid/Low) (m ³ /h)	540/480/420			750/690/630	780/720/660	
	Motor output (W)	22			30		
Connecting pipe	Gas side (mm)	ø9.5			ø12.7		ø15.9
	Liquid side (mm)	ø6.4			ø9.5		
	Drain port (nominal dia.)	25 (Polyvinyl chloride tube)					
Sound pressure level*2 (High/Mid/Low)	(dB(A))	42/39/34			37/35/32	38/36/34	

* Figures in parentheses are for ceiling panels.

Note 1 : The capacities are measured under the conditions specified by JIS B 8615 based on the reference piping.

The reference piping consists of 5 m of main piping and 2.5 m of branch piping connected with 0 m height.

Note 2: The sound level are measured in an anechoic chamber in accordance with JIS B 8616.

Normally, the values measured in the actual operating environment become larger than the indicated values due to the effects of external sound.

Note : Rated conditions Cooling : Indoor air temperature 27°C DB/19°C WB, Outdoor air temperature 35°C DB

MMU-AP0074YH1-E to AP0124YH1-E

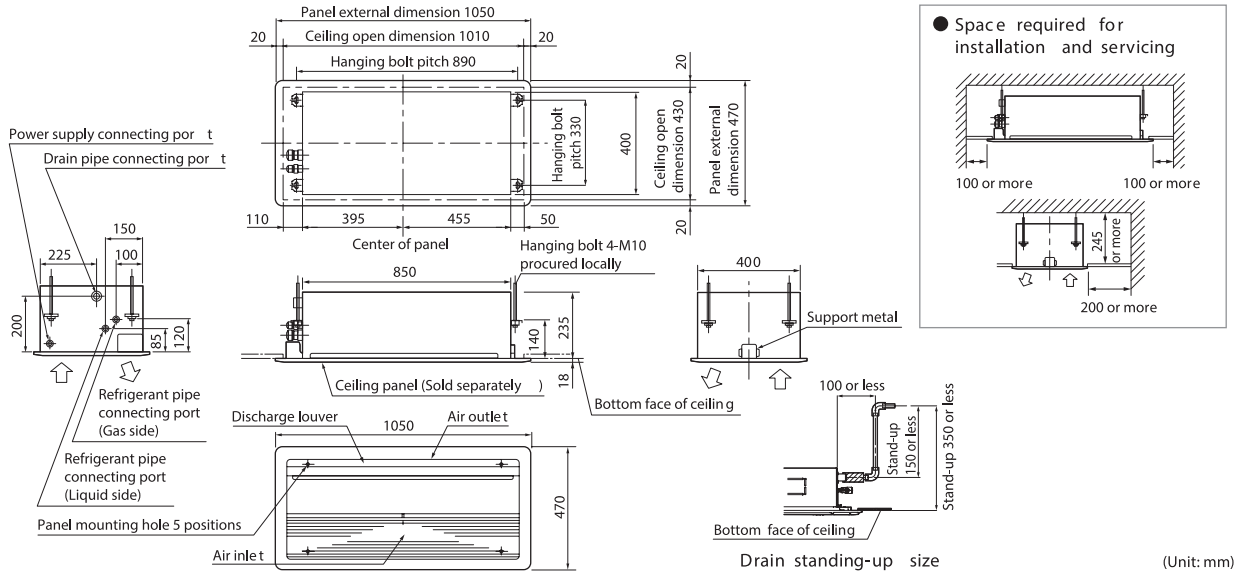

MMU-AP0154SH1-E to AP0244SH1-E

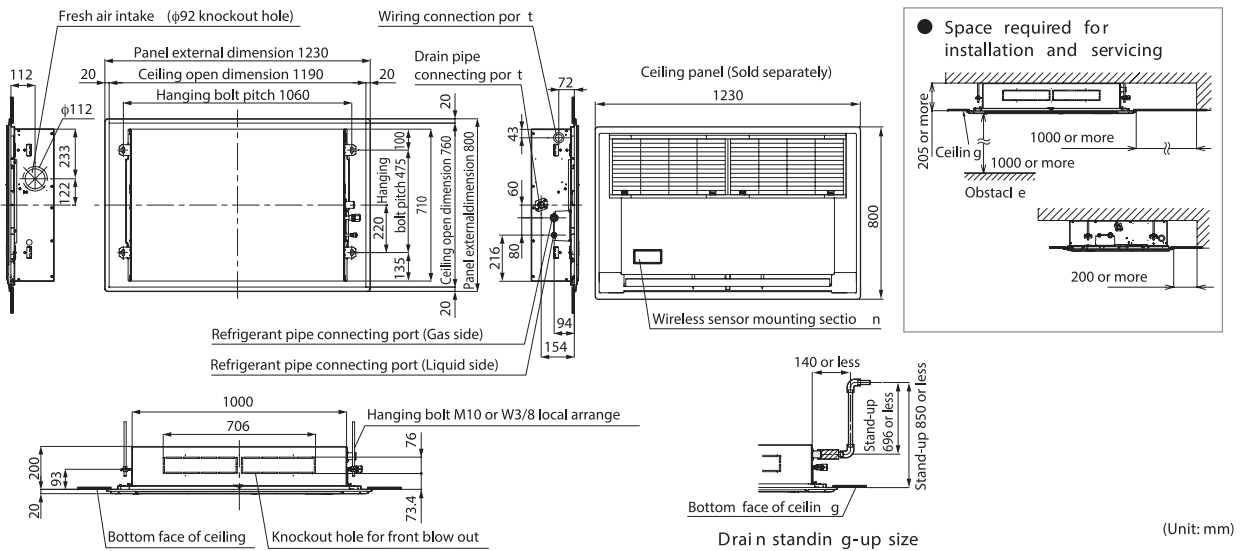

Options

MMU-AP0074YH1-E/AP0094YH1-E/AP0124YH1-E

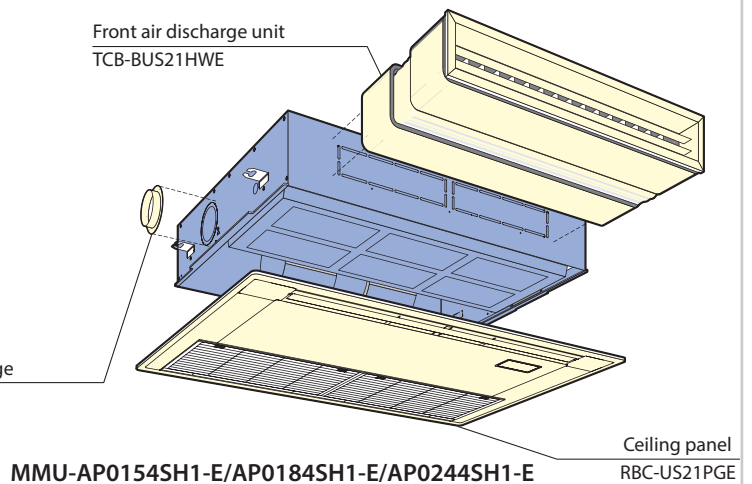
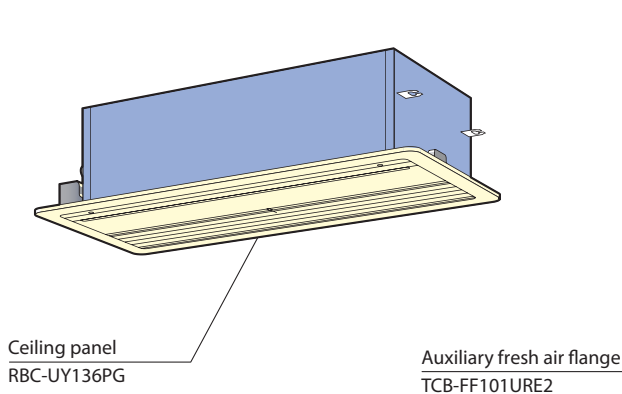

MMU-AP0154SH1-E/AP0184SH1-E/AP0244SH1-E

Slim duct type
MMD-AP*4SPH1-E**

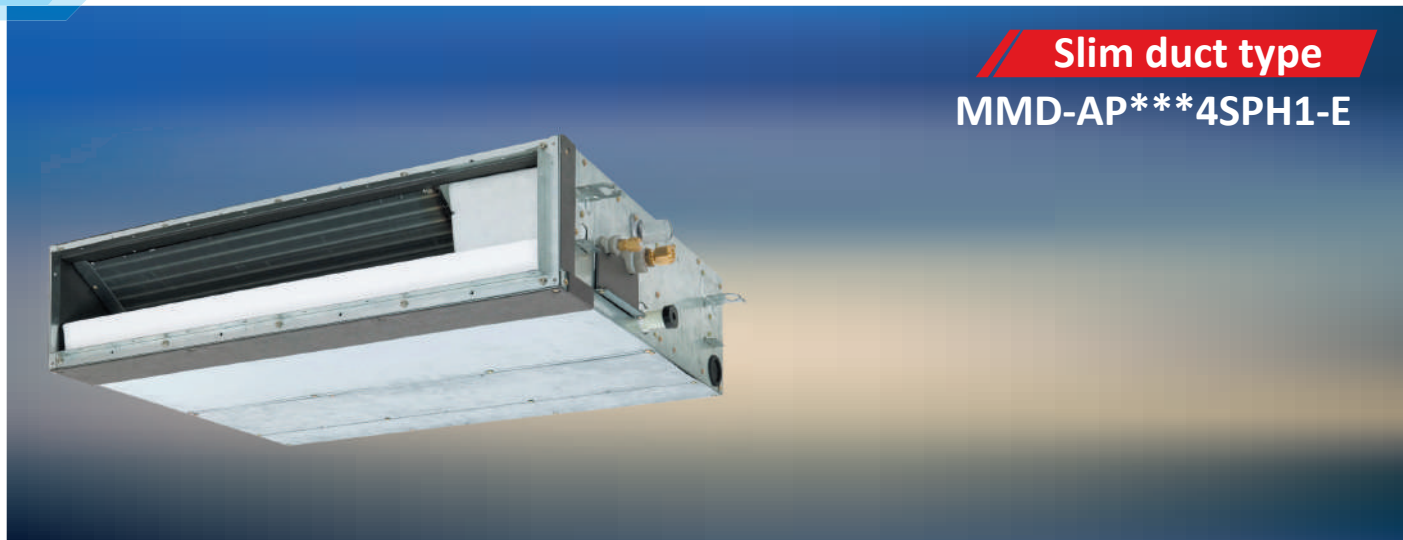

◀ **Functional design**

Only 210 mm in height for greater application flexibility. 4-step static pressure setup. Concealed installation within a ceiling void. Auxiliary fresh air intake available

◀ **Slim & quiet**

Perfect comfort throughout the room. Can be used with any style of air diffuser. Quiet, powerful operation.

Technical specifications

Model name	MMD-	AP0074SPH1-E	AP0094SPH1-E	AP0124SPH1-E	AP0154SPH1-E	AP0184SPH1-E	AP0244SPH1-E	AP0274SPH1-E	
Cooling capacity*1	(kW)	2.2	2.8	3.6	4.5	5.6	7.1	8.0	
Electrical characteristics	Power requirements	1-phase 50Hz 230V (220-240V) / 1-phase 60Hz 220V (Separate power supply for indoor units required.)							
	Power consumption 50 Hz/60 Hz (kW)	0.039/0.037		0.043/0.041	0.045/0.043	0.054/0.052	0.105//0.105		
External dimensions	Height (mm)	210							
	Width (mm)	845					1140		
	Depth (mm)	645							
Total weight (kg)		22			23		29		
Fan unit	Standard air flow (High/Mid/Low) (m³/h)	540/470/400		600/520/450	690/600/520	780/680/580	1080/1000/900		
	Motor output (W)	60							
	External static pressure (Pa)	6-16-31-46 (4 steps)		5-15-30-45 (4 steps)		4-14-29-44 (4 steps)	2-12-22-42 (4 steps)		
Connecting pipe	Gas side (mm)	ø9.5			ø12.7		ø15.9		
	Liquid side (mm)	ø6.4							
	Drain port (nominal dia.)	25 (Polyvinyl chloride tube)							
Sound pressure level*2 (High/Med./Low)	Under air inlet (dB(A))	36/33/30		38/35/32	39/36/33	40/38/36	49/47/44		
	Back air inlet (dB(A))	28/26/24		29/27/25	32/30/28	33/31/29	38/36/33		

Note 1 : The capacities are measured under the conditions specified by JIS B 8615 based on the reference piping. The reference piping consists of 5 m of main piping and 2.5 m of branch piping connected with 0 m height.
 Note 2 : The sound level are measured in an anechoic chamber in accordance with JIS B 8616. Normally, the values measured in the actual operating environment become larger than the indicated values due to the effects of external sound.
 Note : Rated conditions Cooling : Indoor air temperature 27°C DB/19°C WB, Outdoor air temperature 35°C DB

MMD-AP0074SPH1-E to AP0184SPH1-E

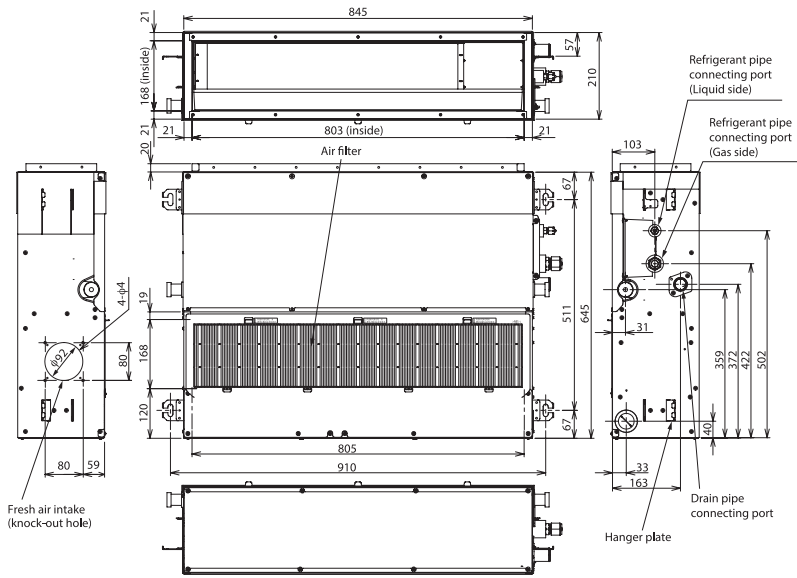

● Space required for installation and servicing

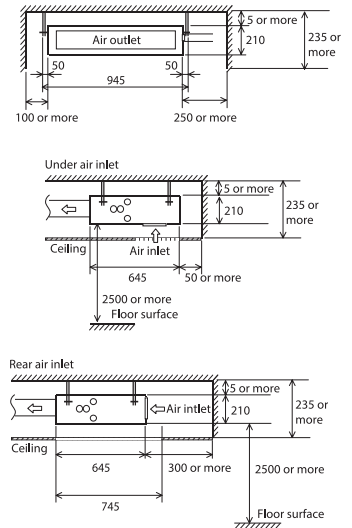

MMD-AP0244SPH1-E to AP0274SPH1-E

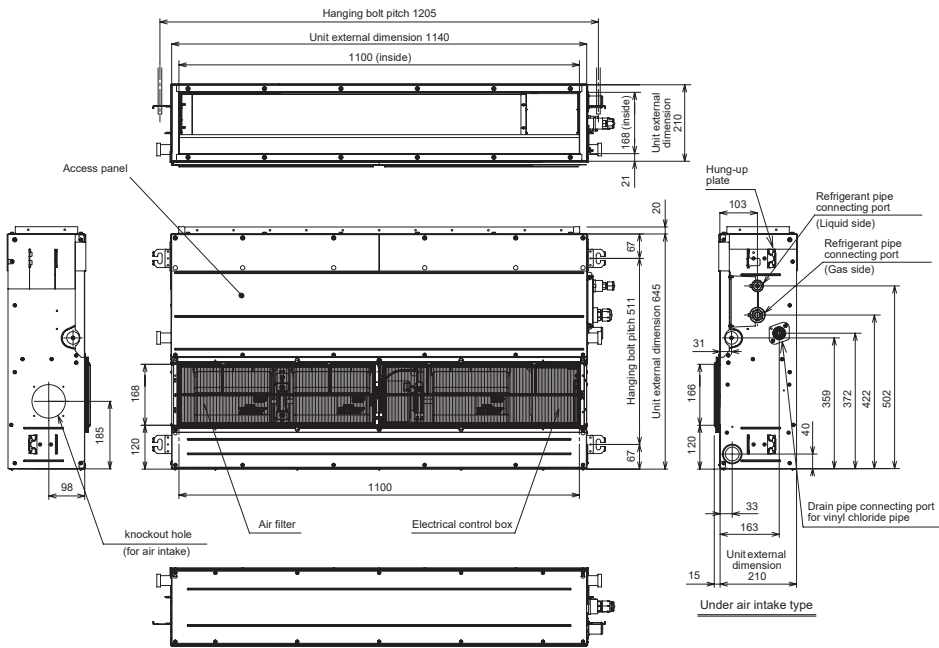

● Space required for installation and servicing

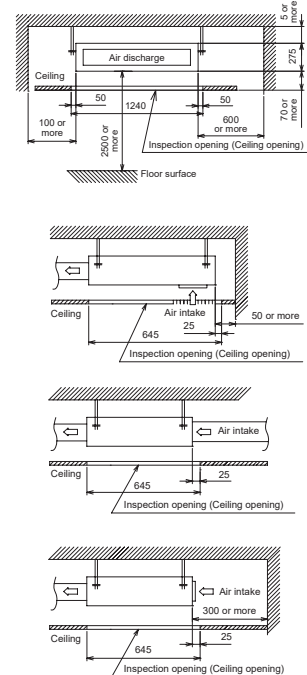

Options

Auxiliary fresh air flange
TCB-FF101URE2

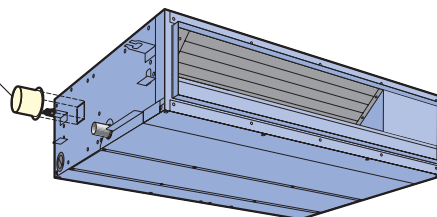

Super slim duct type

MMD-AP*6MPHY**
MMD-AP*6MHY(*3)**

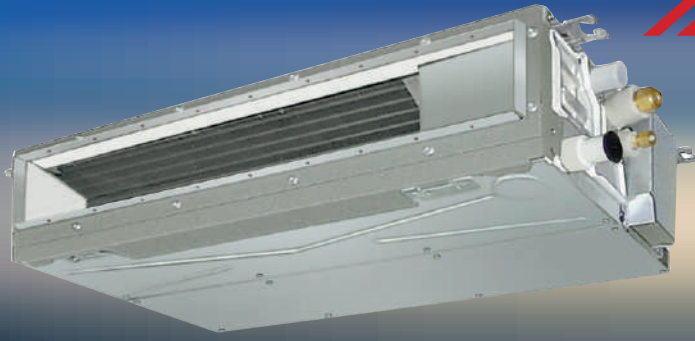

Features

- Very compact design: Only 21 cm height & 45 cm depth
- Wide range choice (12 capacities)
- Easy maintenance - external electrical box
- Choice with high-lift drain pump (350 mm) MPHY or without drain pump MHY(*3)

MMD-AP*6MPHY/MMD-AP***6MHY***

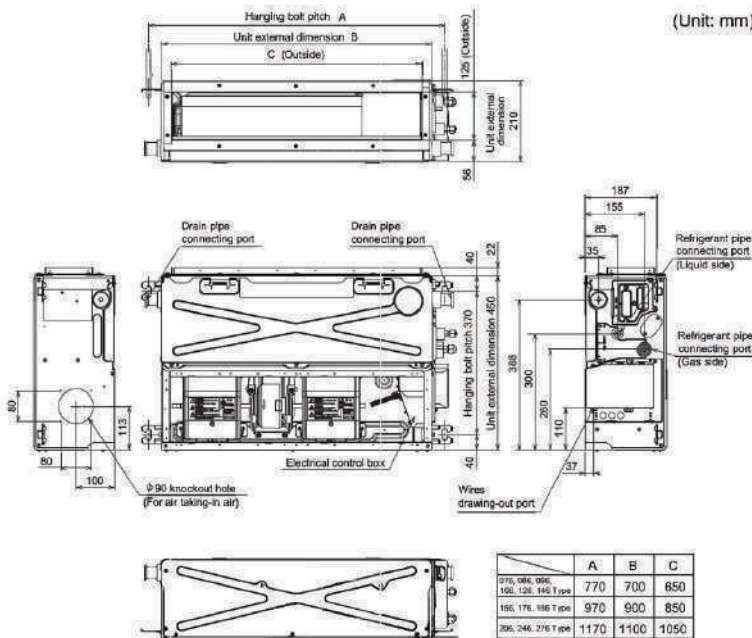

Space required for installation and servicing

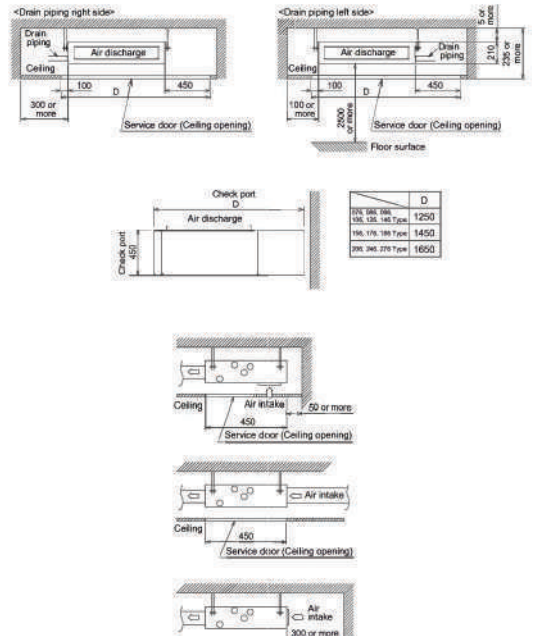

* Standard filter needs to be purchased locally.

Technical specifications

Model name	MMD-	AP0076MPHY AP0076MHY ^(*)	AP0086MPHY AP0086MHY ^(*)	AP0096MPHY AP0096MHY ^(*)	AP0106MPHY AP0106MHY ^(*)	AP0126MPHY AP0126MHY ^(*)	AP0146MPHY AP0146MHY ^(*)	AP0156MPHY AP0156MHY ^(*)	AP0176MPHY AP0176MHY ^(*)	AP0186MPHY AP0186MHY ^(*)	AP0206MPHY AP0206MHY ^(*)	AP0246MPHY AP0246MHY ^(*)	AP0276MPHY AP0276MHY ^(*)				
Cooling capacity ¹⁾	kW	2.2	2.5	2.8	3.2	3.6	4.0	4.5	5.0	5.6	6.3	7.1	8.0				
Electrical characteristics	Power requirements	1-phase 50Hz 230V (220-240V) / 1-phase 60Hz 220V (Separate power supply for indoor units required.)															
	Power consumption (AP***MPHY/AP***MHY)	kW	0.052/ 0.048	0.052/ 0.048	0.052/ 0.048	0.052/ 0.048	0.058/ 0.054	0.058/ 0.054	0.066/ 0.062	0.066/ 0.062	0.066/ 0.062	0.069/ 0.065	0.076/ 0.072	0.076/ 0.072			
External dimensions	Height	mm 210															
	Width	mm 700				mm 900				mm 1100							
	Depth	mm 450															
Total weight	kg	19				22				25							
Fan unit	Standard air flow (High/Mid/Low)	m ³ /h 570/475/380				m ³ /h 610/500/385				m ³ /h 780/580/420				m ³ /h 1000/870/740		m ³ /h 1060/910/760	
	Motor output	W 95															
	External static pressure	Pa 10-20-35-45 (4 steps)															
Connecting pipe	Gas side	mm ø9.5				mm ø12.7				mm ø15.9							
	Liquid side	mm ø6.4															
	Drain port (nominal dia.)	mm 25 (Polyvinyl chloride tube)															
Sound pressure level ²⁾ (High/Mid/Low)	Under air inlet	dB(A) 41/35/30				dB(A) 43/36/30				dB(A) 41/34/27				dB(A) 43/40/37		dB(A) 45/41/38	
	Back air inlet	dB(A) 33/29/25				dB(A) 35/29/25				dB(A) 33/27/22				dB(A) 37/33/30		dB(A) 38/34/31	

Note 1 : The capacities are measured under the conditions specified by JIS B 8615 based on the reference piping. The reference piping consists of 5 m of main piping and 2.5 m of branch piping connected with 0 m height.

Note 2 : The sound level are measured in an anechoic chamber in accordance with JIS B 8616.

Normally, the values measured in the actual operating environment become larger than the indicated values due to the effects of external sound.

Note : Rated conditions Cooling : Indoor air temperature 27°C DB/19°C WB, Outdoor air temperature 35°C DB

Note *3 : Without drain pump



SMMS -7 VRF

Air Conditioning for large building.



Concealed duct high static pressure type



MMD-AP***6HP1-E



MMD-AP***6HP-E

Design flexibility

Satisfies all your design needs.
Compatible with external static pressures up to 250 Pa.

Can be equipped with the following options:

- Long life filter kit
- Drain pump kit

Construction characteristics

Seven-stage-switchable static pressure.
The flexible duct is accessible.
Easy service and installation.
Inspection hole enables easy access and maintenance.

*Built-in Drain-pump : up to 6 HP model

Technical specifications

Model name	MMD-	AP0186HP1-E	AP0246HP1-E	AP0276HP1-E	AP0366HP1-E	AP0486HP1-E	AP0566HP1-E	AP0726HP-E	AP0966HP-E	
Cooling capacity*1	(kW)	5.6	7.1	8.0	11.2	14.0	16.0	22.4	28.0	
Electrical characteristics	Power requirements	1-phase 50Hz 230V (220-240V) / 1-phase 60Hz 220V (Separate power supply for indoor units required.)								
	Power consumption 50 Hz/60 Hz (kW)	0.085/0.085	0.115/0.115		0.198/0.198	0.230/0.230	0.290/0.290	0.540/0.540	0.790/0.790	
External dimensions	Height (mm)	298						448		
	Width (mm)	1,000			1,400			1,400		
	Depth (mm)	750						900		
Total weight (kg)		34			43			97		
Fan unit	Standard air flow (Med./Low) (m ³ /h)	800 (660/550)	1,200 (970/800)		1,920 (1,560/1,340)	2,100 (1,740/1,420)	2,400 (2,040/1,660)	3,800 (3,200/2,500)	4,800 (4,200/3,500)	
	Motor output (W)	250			350			250		
	External static pressure (factory setting) (Pa)	100						150		
	External static pressure (Pa)	50-75-125-150-175-200 (7steps)						50-83-117-150-183-217-250 (7steps)		
Connecting pipe	Gas side (mm)	ø12.7	ø15.9			ø22.2				
	Liquid side (mm)	ø6.4	ø9.5			ø12.7				
	Drain port (nominal dia.)	25 (Polyvinyl chloride tube)						25 (Polyvinyl chloride tube)		
Sound pressure level*2 (High/Mid/Low) (dB(A))		37 (32/30)	38 (34/31)		41 (37/34)	42 (40/35)	45 (42/37)	44 (40/36)	46 (42/38)	

Note 1 : The cooling capacities and electrical characteristics are measured under the conditions specified by JIS B 8615 based on the reference piping. The reference piping consists of 5m of main piping and 2.5 of branch piping connected with 0 meter height.

Note 2 : The sound level are measured in an anechoic chamber in accordance with JIS B 8616.

Normally, the values measured in the actual operating environment become larger than the indicated values due to the effects of external sound.

Note : Rated conditions Cooling : Indoor air temperature 27°C DB/19°C WB, Outdoor air temperature 35°C DB

MMD-AP0186HP1-E to AP0276HP1-E

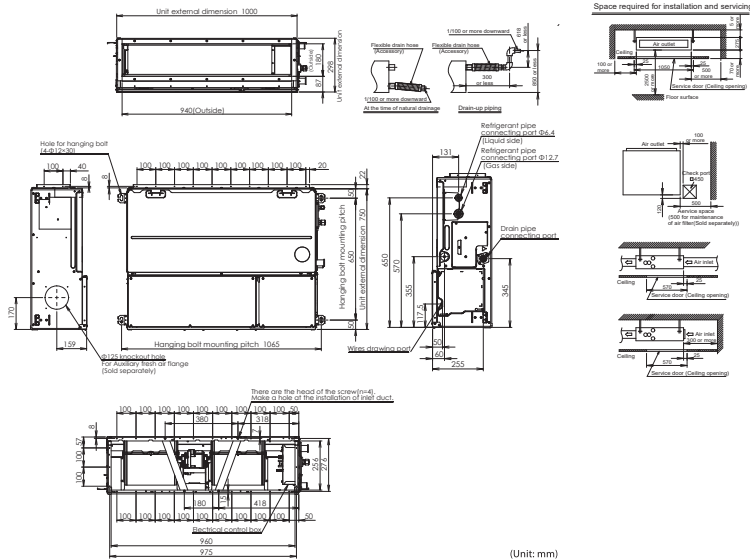

(Unit: mm)

MMD-AP0726HP-E, AP0966HP-E

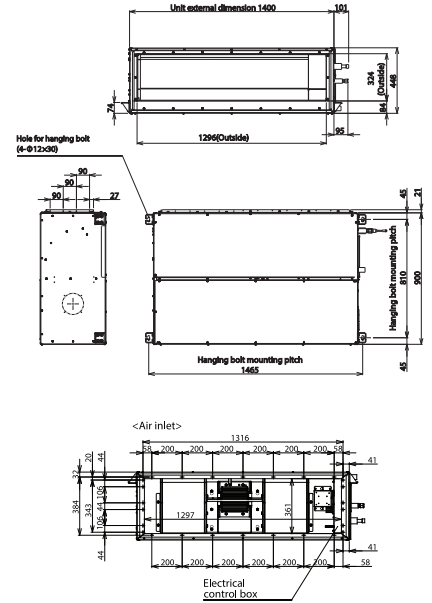

(Unit: mm)

MMD-AP0366HP1-E to AP0566HP1-E

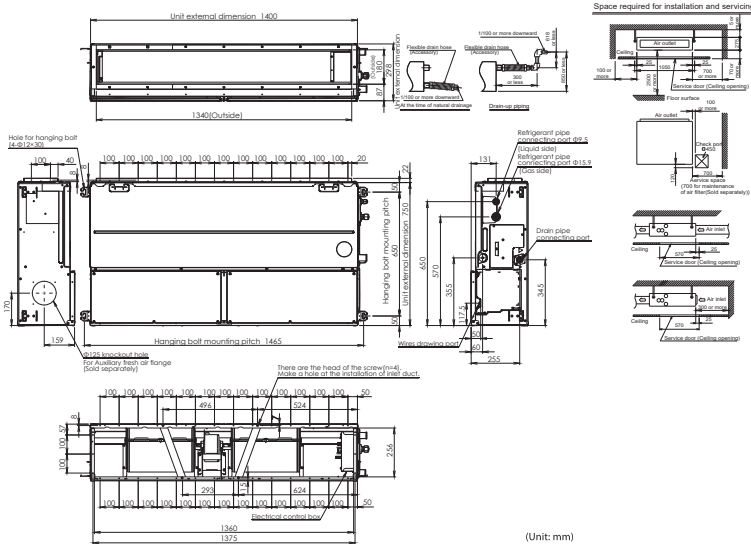

(Unit: mm)

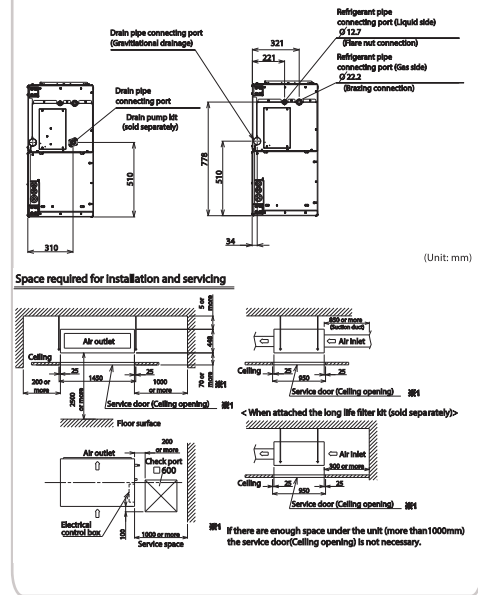

(Unit: mm)

Options

TCB-LK801D-E
TCB-LK1401D-E

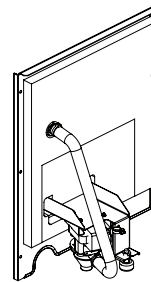
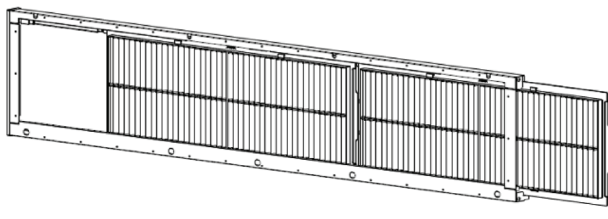

TCB-DP40DPE
Drain Pump kit for 8,10 HP

TCB-LK2801DP-E

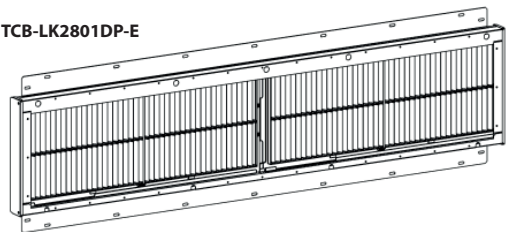

Option Parts	Model Name	Application FCU
Long life filter kit*	TCB-LK801D-E	MMD-AP0186/0246/0276HP1-E
Long life filter kit*	TCB-LK1401D-E	MMD-AP0366/0486/0566HP1-E
Long life filter kit*	TCB-LK2801DP-E	MMD-AP0726/0966HP-E

- * Long Life Filter Kit ;
- Flange shaped
 - Mount chassis directly
 - Upside down mountable
 - Removable to both left and right

Concealed duct type

MMD-AP***6BHP1-E

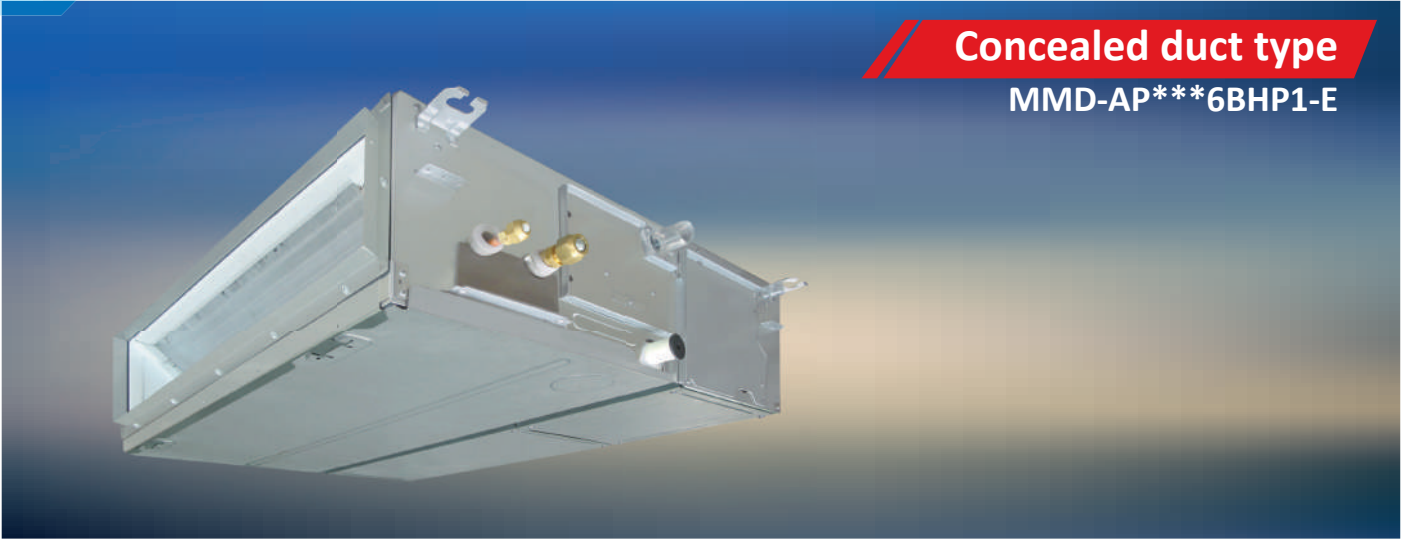

High static pressure

External static pressure can be raised as high as 120 Pa, so that all areas of the room can be reached for even temperature distribution, no matter how complex the layout.

High-lift drain pump

Built-in high-lift drain pump up to 850 mm.

Technical specifications

Model name	MMD-	AP0076BHP1-E	AP0096BHP1-E	AP0126BHP1-E	AP0156BHP1-E	AP0186BHP1-E	AP0246BHP1-E	AP0276BHP1-E	AP0306BHP1-E	AP0366BHP1-E	AP0486BHP1-E	AP0566BHP1-E	
Cooling capacity*1	(kW)	2.2	2.8	3.6	4.5	5.6	7.1	8.0	9.0	11.2	14.0	16.0	
Electrical characteristics	Power requirements	1-phase 50Hz 230V (220-240V) / 1-phase 60Hz 220V (Separate power supply for indoor units required.)											
	Power consumption 50 Hz/60 Hz (kW)	0.038/0.038	0.043/0.043	0.062/ 0.062		0.077/0.077		0.094/ 0.094	0.172/ 0.172	0.198/0.198			
External dimension	Height (mm)	275											
	Width (mm)	700			700		1,000			1,400			
	Depth (mm)	750											
Total weight	(kg)	23					30			40			
Fan unit	Standard air flow (Mid/Low) (m ³ /h)	540/450/360	570/480/390	798/660/540		1,200/990/870		1,260/1,110/930	1,920/1,620/1,380	2,100/1,740/1,500			
	Motor output (W)	150											
	External static pressure (factory setting) (Pa)	30					40			50			
	External static pressure (Pa)	30-40-50-65-80-100-120 (7 steps)											
Connecting pipe	Gas side (mm)	ø9.5			ø12.7		ø15.9						
	Liquid side (mm)	ø6.4					ø9.5						
	Drain port dia.) (nominal)	25 (Polypropylene tube)											
Sound pressure level*2 (High/Mid/Low) (dB(A))		29/26/23	30/26/23		33/29/25		36/31/27			40/36/33			

Note 1 : The capacities are measured under the conditions specified by JIS B 8615 based on the reference piping.

The reference piping consists of 5 m of main piping and 2.5 m of branch piping connected with 0 m height.

Note 2 : The sound level are measured in an anechoic chamber in accordance with JIS B 8616.

Normally, the values measured in the actual operating environment become larger than the indicated values due to the effects of external sound.

Note : Rated conditions : Cooling : Indoor air temperature 27°C DB/19°C WB, Outdoor air temperature 35°C DB

MMD-AP0076BHP1-E to AP0566BHP1-E

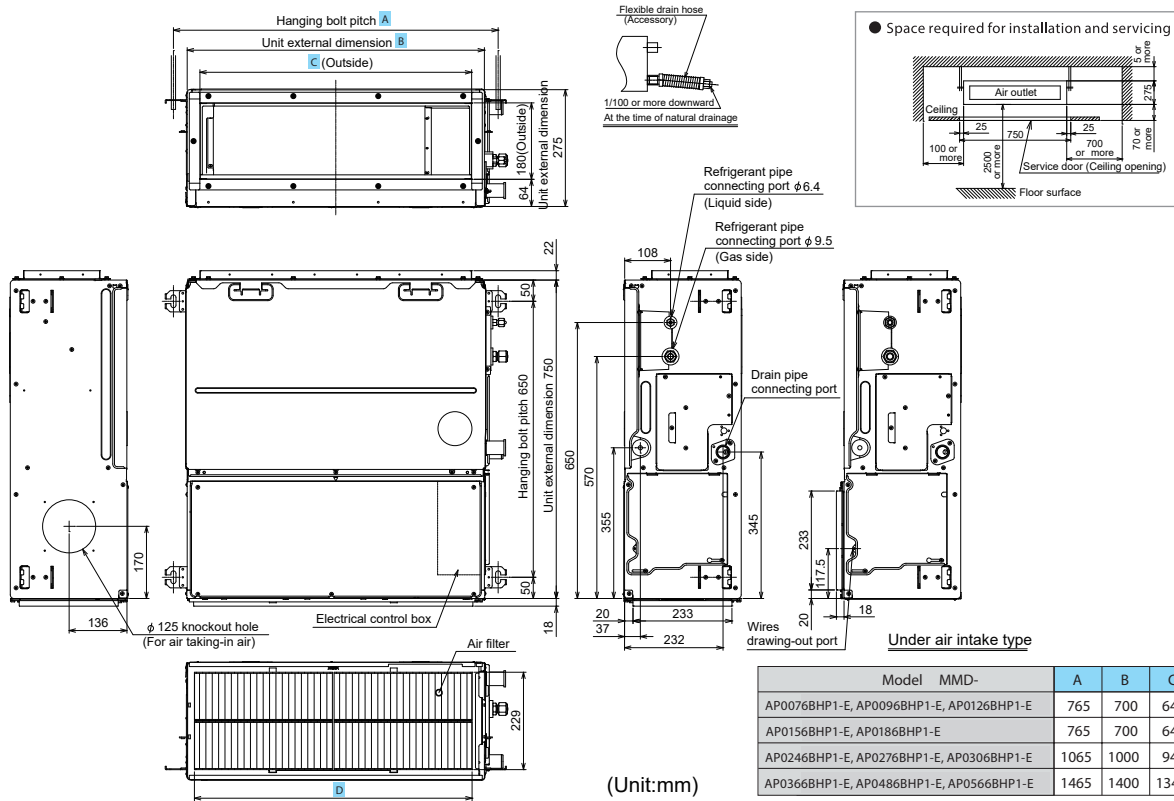

Model	MMD-	A	B	C	D
AP0076BHP1-E, AP0096BHP1-E, AP0126BHP1-E		765	700	640	654
AP0156BHP1-E, AP0186BHP1-E		765	700	640	654
AP0246BHP1-E, AP0276BHP1-E, AP0306BHP1-E		1065	1000	940	953.5
AP0366BHP1-E, AP0486BHP1-E, AP0566BHP1-E		1465	1400	1340	1349

(Unit:mm)

* Standard filter is provided, but deeper filtration filter needs to be purchased locally.

Options

Spigot shaped flange

- TCB-SF56C6BPE
- TCB-SF80C6BPE
- TCB-SF160C6BPE

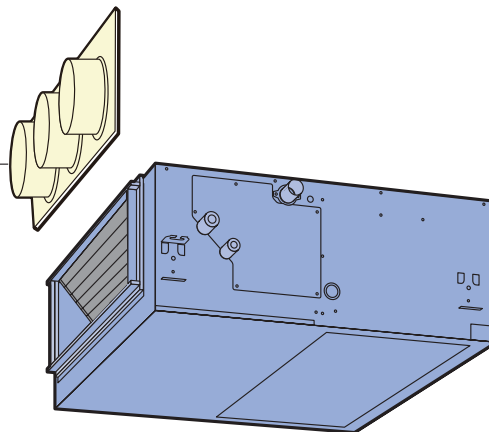

Ceiling type

MMC-AP***8HP-E



Smooth curve for pliant shape

All-new chassis and new rounded design, This new models have been developed in response to customers' needs for ceiling units that better match their room interiors.

New fan has adopted the turbulence prevention rib to optimize the ventilating way.

Air volume has increased and noise level also has decreased compared with previous model. Winds of new ceiling type of 4HP to 6HP can be reached up to 4.3 metre

New designed wide flap

The new air outlet has realized both high noise reduction and large air volume.

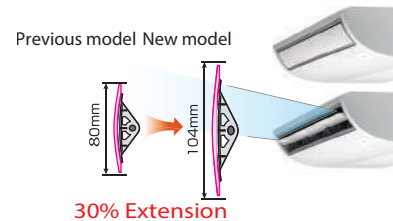

Temperature measuring section

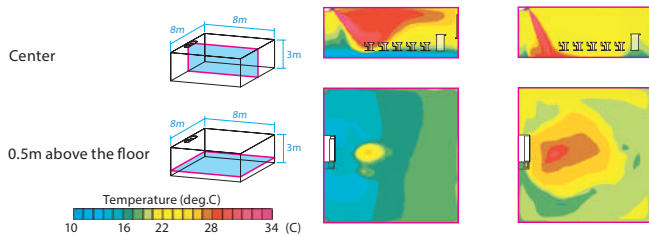

Flap control

The airflow angle is automatically set to the most suitable setting according to your cooling or heating needs, and an automatic swing mode enables airflow to reach all areas of the room to create a comfortable ambience.

Technical specifications

Model name		MMC-	AP0158HP-E	AP0188HP-E	AP0248HP-E	AP0278HP-E	AP0368HP-E	AP0488HP-E	AP0568HP-E	
Cooling capacity*1		(kW)	4.5	5.6	7.1	8.0	11.2	14.0	16.0	
Electrical characteristics	Power requirements	1-phase 50Hz 230V (220-240V) / 1-phase 60Hz 220V (Separate power supply for indoor units required.)								
	Power consumption 50 Hz/60 Hz (kW)		0.033/0.033	0.034/0.034	0.067/0.067		0.083/0.083		0.111/0.111	
External dimensions	Height (mm)	235								
	Width (mm)	950			1,269		1,586			
	Depth (mm)	690								
Total weight (kg)			24		30		37			
Fan unit	Standard air flow (High/Mid/Low) (m ³ /h)		840 /690/540	960 /720/540		1440 /1020/750		1860 /1350/1020	1860 /1530/1200	2040 /1650/1260
	Motor (W)		94		94		139			
Connecting pipe	Gas side (mm)		ø12.7		ø15.9					
	Liquid side (mm)		ø6.4		ø9.5					
	Drain port (nominal dia.)		20 (Polyvinyl chloride tube)							
Sound pressure level*2 (High/Mid/Low) (dB(A))			36/34/28	37/35/28		41/36/29		44/38/32	44/41/35	46/42/36

Note 1 : The capacities are measured under the conditions specified by JIS B 8615 based on the reference piping.

The reference piping consists of 5 m of main piping and 2.5 m of branch piping connected with 0 m height.

Note 2 : The sound level are measured in an anechoic chamber in accordance with JIS B 8616.

Normally, the values measured in the actual operating environment become larger than the indicated values due to the effects of external sound.

Note : Rated conditions Cooling : Indoor air temperature 27°C DB/19°C WB, Outdoor air temperature 35°C DB

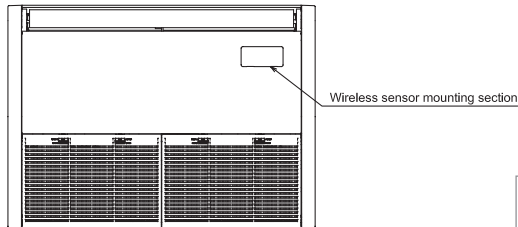
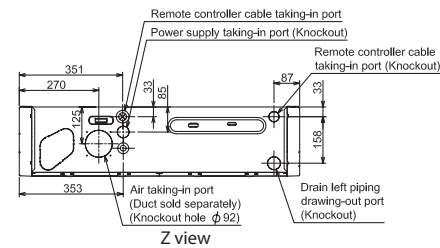
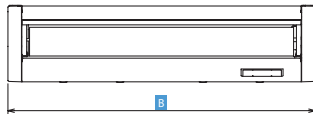
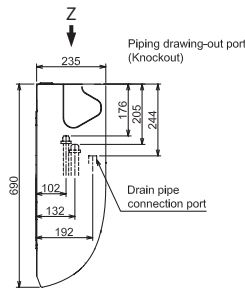
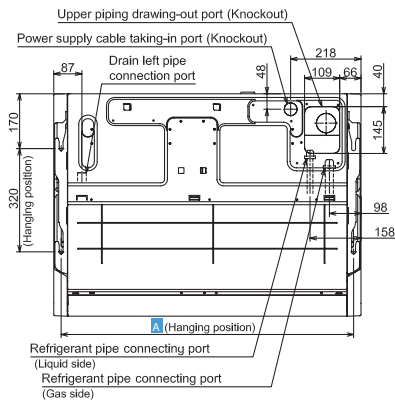

Model MMC-	A	B
AP0158HP-E, AP0188HP-E	906	950
AP0248HP-E, AP0278HP-E	1,223	1,270
AP0368HP-E, AP0488HP-E, AP0568HP-E	1,540	1,586

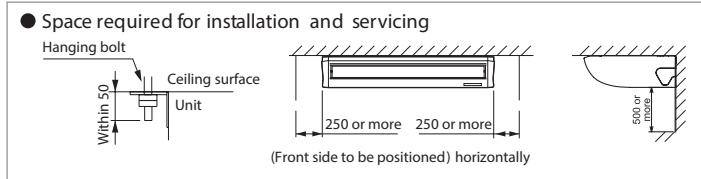

(Unit: mm)

Options

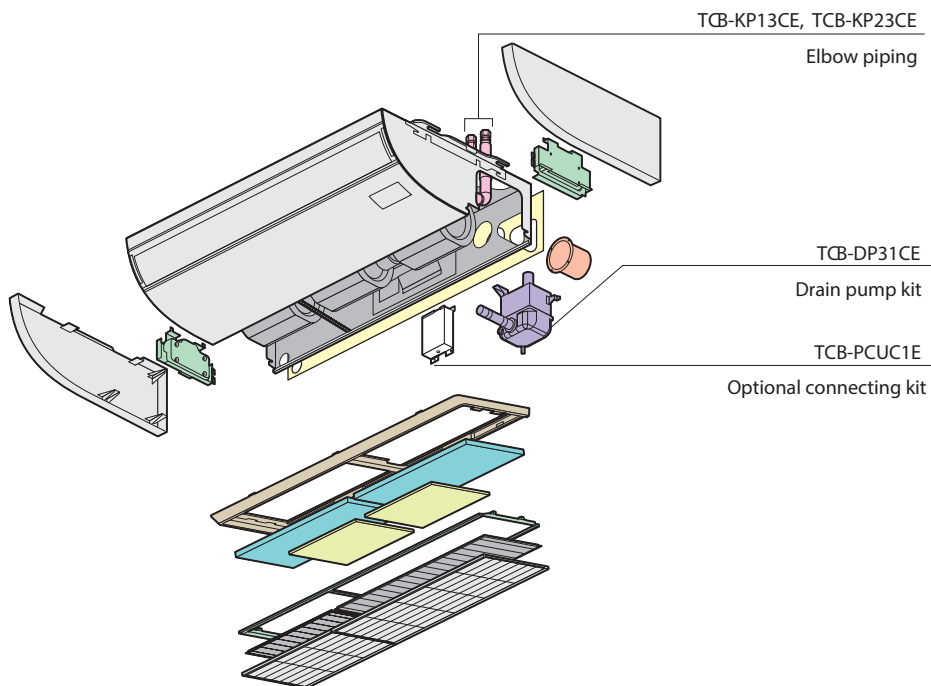

High wall type (series 7)

MMK-AP*7HP-E**

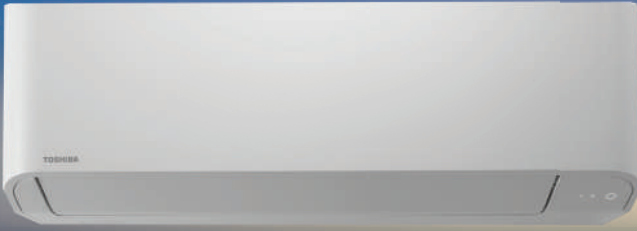

Compact and aesthetic design

Glossy material, smooth, curve and white LED are designed to reflect luxurious appearance and to complement modern exterior beautifully.



Remote controller

* Wireless remote controller is packed with indoor unit.

MMK-AP0077HP-E to MMK-AP0247HP-E

MMK-AP0077HP-E to MMK-AP0127HP-E

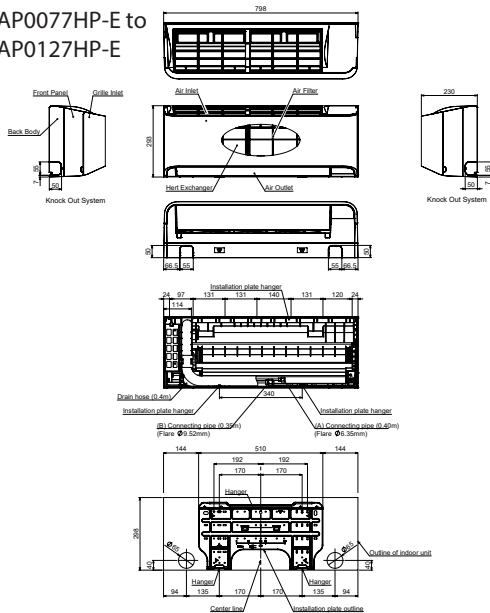

MMK-AP0157HP-E to MMK-AP0247HP-E

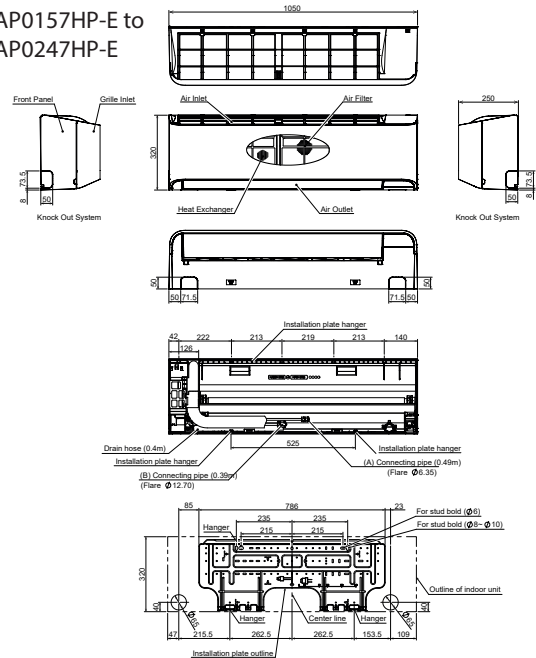

Technical specifications

Model name	MMK-	AP0077HP-E	AP0097HP-E	AP0127HP-E	AP0157HP-E	AP0187HP-E	AP0247HP-E	
Cooling/Heating capacity*1	(kW)	2.2/2.5	2.8/3.2	3.6/4.0	4.5/5.0	5.6/6.3	7.1/8.0	
Electrical characteristics	Power requirements	1-phase 50 Hz 230V (220-240V) (Separate power supply for indoor units required)						
	Power consumption 50 Hz	(kW)	0.015	0.016	0.017	0.028	0.032	0.050
External dimensions	Height	(mm)	293		320			
	Width	(mm)	798		1050			
	Depth	(mm)	230		250			
Total weight	(kg)	11		16				
Fan unit	Standard air flow (High/Mid/Low)	(m ³ /h)	480/385/270	510/395/270	540/410/300	840/690/550	900/720/550	1200/900/600
	Motor output	(W)	30					
Connecting pipe	Gas side	(mm)	ø9.5		ø6.4		ø9.5	
	Liquid side	(mm)	ø6.4		ø12.7		ø15.9	
	Drain port	(nominal dia. mm)	16 (Polyvinyl chloride tube)					
Sound pressure level*2 (High/Mid/Low)	(dB(A))	35/30/25	36/31/25	37/32/25	40/36/32	41/37/32	45/39/33	

Note 1 : The capacities are measured under the conditions specified by JIS B 8615 based on the reference piping. The reference piping consists of 5 m of main piping and 2.5 m of branch piping connected with 0 m height.

Note 2 : The sound level are measured in an anechoic chamber in accordance with JIS B 8616.

Normally, the values measured in the actual operating environment become larger than the indicated values due to the effects of external sound.

Note : Rated conditions Cooling : Indoor air temperature 27°C DB/19°C WB, Outdoor air temperature 35°C DB
Heating : Indoor air temperature 20°C DB, Outdoor air temperature 7°C DB/6°C WB

High wall type (large capacity)

MMK-UP***1HP-E

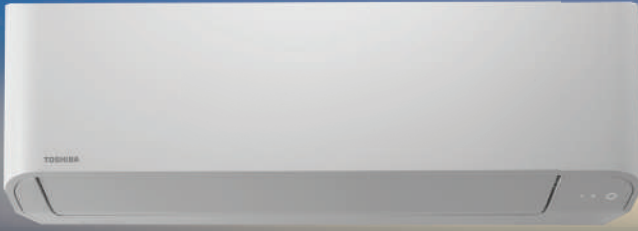

Compact and aesthetic design

Glossy material, smooth, curve and white LED are designed to reflect luxurious appearance and to complement modern exterior beautifully.



Remote controller

* Wireless remote controller is packed with indoor unit.

MMK-UP0271HP-E to MMK-UP0361HP-E

MMK-UP0271HP-E to MMK-UP0361HP-E

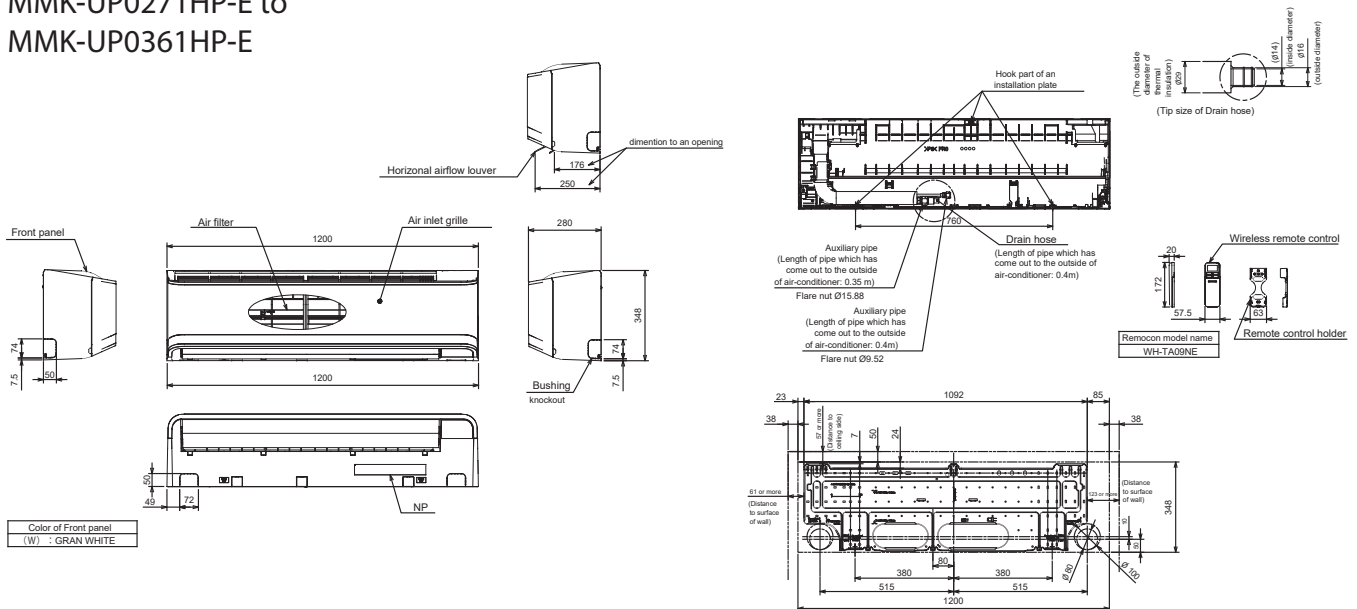

Technical specifications

Model name	MMK-	UP0271HP-E	UP0301HP-E	UP0361HP-E
Cooling/Heating capacity* ¹	(kW)	8.0/9.0	9.0/10.0	11.2/12.5
Electrical characteristics	Power requirements	1-phase 50 Hz 230V (220-240V) (Separate power supply for indoor units required)		
	Power consumption 50 Hz (kW)	0.034	0.054	0.066
External dimensions	Height (mm)	348		
	Width (mm)	1200		
	Depth (mm)	280		
Total weight (kg)	21			
Fan unit	Standard air flow (High/Mid/Low) (m ³ /h)	1200/1000/800	1500/1300/1100	1650/1350/1250
	Motor output (W)	61		
Connecting pipe	Gas side (mm)	$\varnothing 15.9$		
	Liquid side (mm)	$\varnothing 9.5$		
	Drain port (nominal dia. mm)	16 (Polyvinyl chloride tube)		
Sound pressure level* ² (High/Mid/Low) (dB(A))		43/41/39	48/44/41	50/45/43

Note 1 : The capacities are measured under the conditions specified by JIS B 8615 based on the reference piping. The reference piping consists of 5 m of main piping and 2.5 m of branch piping connected with 0 m height.

Note 2 : The sound level are measured in an anechoic chamber in accordance with JIS B 8616.

Normally, the values measured in the actual operating environment become larger than the indicated values due to the effects of external sound.

Note : Rated conditions Cooling : Indoor air temperature 27°C DB/19°C WB, Outdoor air temperature 35°C DB
Heating : Indoor air temperature 20°C DB, Outdoor air temperature 7°C DB/6°C WB

Floor standing concealed type

MML-AP*4BH1-E**

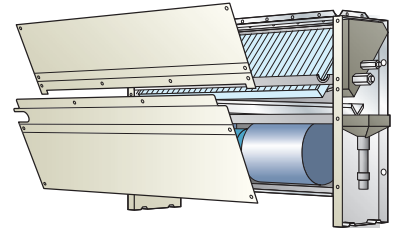

- ◀ **Cool air makes for a pleasant indoor environment**
Install it under a window and air-condition any room effectively.
- ◀ **Easy maintenance**
Simplified design of fan and drainage pipe eases maintenance.

MML-AP0074BH1-E to AP0244BH1-E

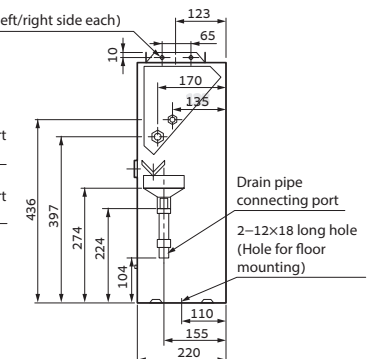
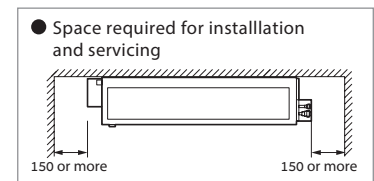
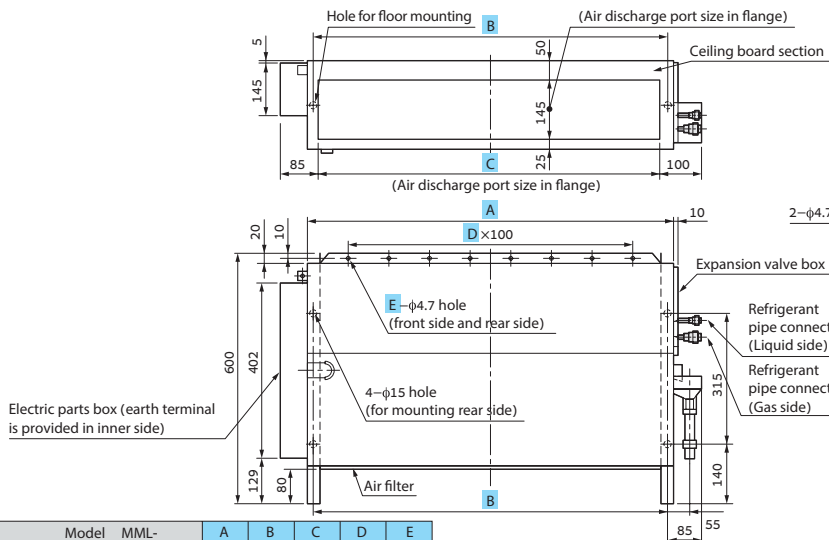

Model	MML-	A	B	C	D	E
AP0074BH1-E to AP0124BH1-E		610	580	550	4	5
AP0154BH1-E to AP0244BH1-E		910	880	850	7	8

(Unit: mm)

Technical specifications

Model name	MML-	AP0074BH1-E	AP0094BH1-E	AP0124BH1-E	AP0154BH1-E	AP0184BH1-E	AP0244BH1-E			
Cooling capacity*1	(kW)	2.2	2.8	3.6	4.5	5.6	7.1			
Electrical characteristics	Power requirements	1-phase 50Hz 230V (220-240V) / 1-phase 60Hz 220V (Separate power supply for indoor units required.)								
	Power consumption 50 Hz/60 Hz	(kW)			0.056/0.058		0.090/0.096	0.095/0.110		
External dimensions	Height	(mm)						600		
	Width	(mm)						74		
	Depth	(mm)						220		
Total weight	(kg)	21				29				
Fan unit	Standard air flow (High/Mid/Low)	(m³/h)			460/400/300		740/600/490	950/790/640		
	Motor output	(W)						19	70	
Connecting pipe	Gas side	(mm)						φ9.5	φ12.7	φ15.9
	Liquid side	(mm)						φ6.4		φ9.5
	Drain port	(nominal dia.)						20 (Polyvinyl chloride tube)		
Sound pressure level*2 (High/Mid/Low)	(dB(A))							36/34/3	2/37/33	

Note 1 : The capacities are measured under the conditions specified by JIS B 8615 based on the reference piping. The reference piping consists of 5 m of main piping and 2.5 m of branch piping connected with 0 m height.
 Note 2 : The sound level are measured in an anechoic chamber in accordance with JIS B 8616.
 Normally, the values measured in the actual operating environment become larger than the indicated values due to the effects of external sound.
 Note : Rated conditions Cooling : Indoor air temperature 27°C DB/19°C WB, Outdoor air temperature 35°C DB

Floor standing cabinet type

MML-AP***4H1-E



Slim & compact design

Under-window mounting does not block lighting.
Indoor unit size of 2.2 kW to 7.1 kW is the same.
Distribution can be reversed to suit occupant preference.

Air blow from front panel
(factory default)

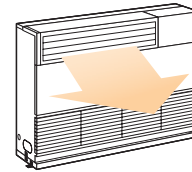

Air blow from top

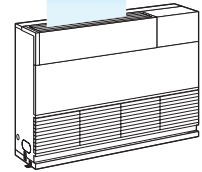

MML-AP0074H1-E to AP0244H1-E

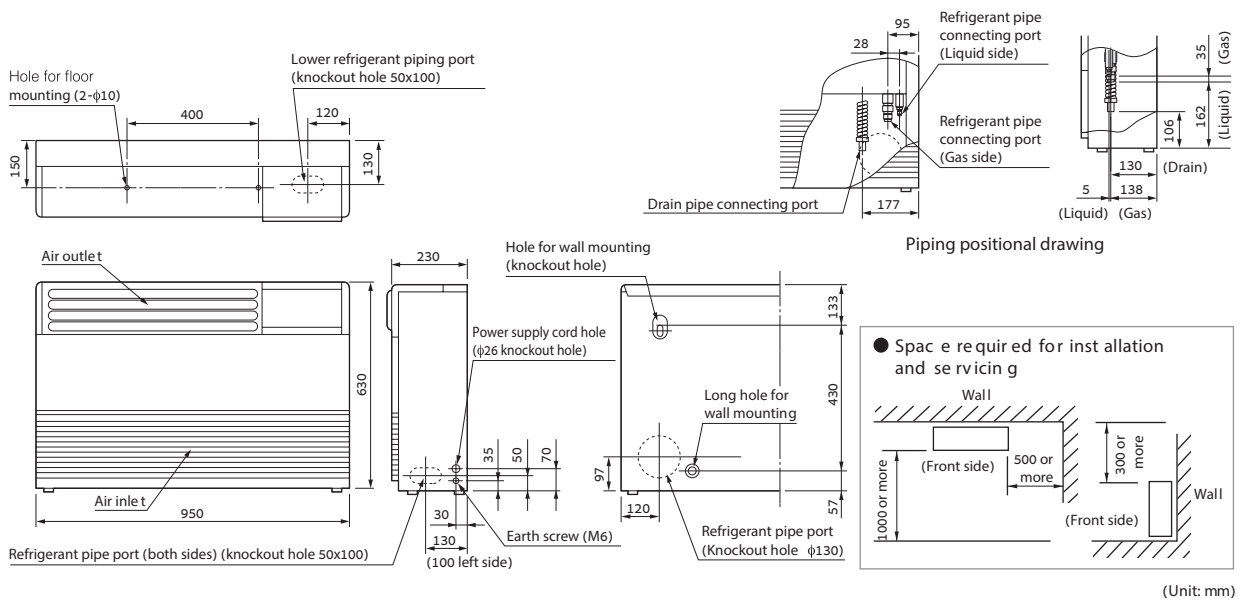

Technical specifications

Model name	MML-	AP0074H1-E	AP0094H1-E	AP0124H1-E	AP0154H1-E	AP0184H1-E	AP0244H1-E	
Cooling capacity*1	(kW)	2.2	2.8	3.6	4.5	5.6	7.1	
Electrical characteristics	Power requirements	1-phase 50Hz 230V (220-240V) / 1-phase 60Hz 220V (Separate power supply for indoor units required.)						
	Power consumption 50 Hz/60 Hz	(kW) 0.056/0.053		0.092/0.092		0.102/0.113		
External dimensions	Height	(mm) 630						
	Width	(mm) 950						
	Depth	(mm) 230						
Total weight	(kg)	37			40			
Fan unit	Standard air flow (High/Mid/Low)	(m ³ /h) 480/420/360		900/780/650		1080/930/780		
	Motor output	(W) 45						
Connecting pipe	Gas side	(mm) φ9.5			φ12.7		φ15.9	
	Liquid side	(mm) φ6.4						
	Drain port	(nominal dia.) 20 (Polyvinyl chloride tube)						
Sound pressure level*2 (High/Mid/Low)	(dB(A))	39/37/35		45/41/38		49/44/39		

Note 1: The capacities are measured under the conditions specified by JIS B 8615 based on the reference piping.

The reference piping consists of 5 m of main piping and 2.5 m of branch piping connected with 0 m height.

Note 2: The sound level are measured in an anechoic chamber in accordance with JIS B 8616.

Normally, the values measured in the actual operating environment become larger than the indicated values due to the effects of external sound.

Note: Rated conditions Cooling: Indoor air temperature 27°C DB/19°C WB, Outdoor air temperature 35°C DB

Console type

MML-AP*4NH1-E**



Elegant & simple design

Elegant & simple design makes this unit a perfect fit for shops, office buildings, and luxury apartments. Multi-function operation is convenient, making adjustments by the user possible using the wireless remote controller.



Remote controller

* Wireless remote controller is packed with indoor unit.

MML-AP0074NH1-E to AP0184NH1-E

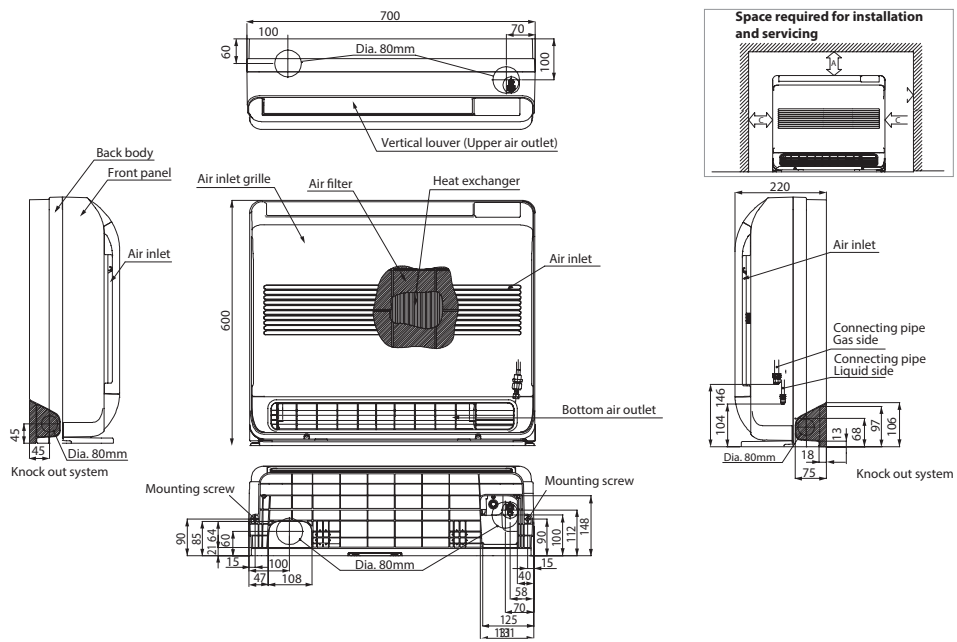

(Unit: mm)

Technical specifications

Model name	MML-	AP0074NH1-E	AP0094NH1-E	AP0124NH1-E	AP0154NH1-E	AP0184NH1-E
Cooling capacity*1	(kW)	2.2	2.8	3.6	4.5	5.6
Electrical characteristics	Power requirements	1-phase 50Hz 230V (220-240V) / 1-phase 60Hz 220V (Separate power supply for indoor units required.)				
	Power consumption 50 Hz/60 Hz	(kW)	0.021/0.021	0.025/0.025	0.034/0.034	0.052/0.052
External dimensions	Height	(mm)	600			
	Width	(mm)	700			
	Depth	(mm)	220			
Total weight	(kg)	17				
Fan unit	Standard air flow (High/Mid/Low)	(m ³ /h)	510/366/282	552/408/324	624/468/384	726/528/426
	Motor output	(W)	41			
Connecting pipe	Gas side	(mm)	ø9.5		ø12.7	
	Liquid side	(mm)	ø6.4			
	Drain port	(nominal dia.)	16 (Polyvinyl chloride tube)			
Sound pressure level*2 (High/Mid/Low)	(dB(A))	38/32/26		40/34/29	43/37/31	47/40/34

Note 1 : The capacities are measured under the conditions specified by JIS B 8615 based on the reference piping.

The reference piping consists of 5 m of main piping and 2.5 m of branch piping connected with 0 m height.

Note 2 : The sound level are measured in an anechoic chamber in accordance with JIS B 8616.

Normally, the values measured in the actual operating environment become larger than the indicated values due to the effects of external sound.

Note : Rated conditions Cooling : Indoor air temperature 27°C DB/19°C WB, Outdoor air temperature 35°C DB

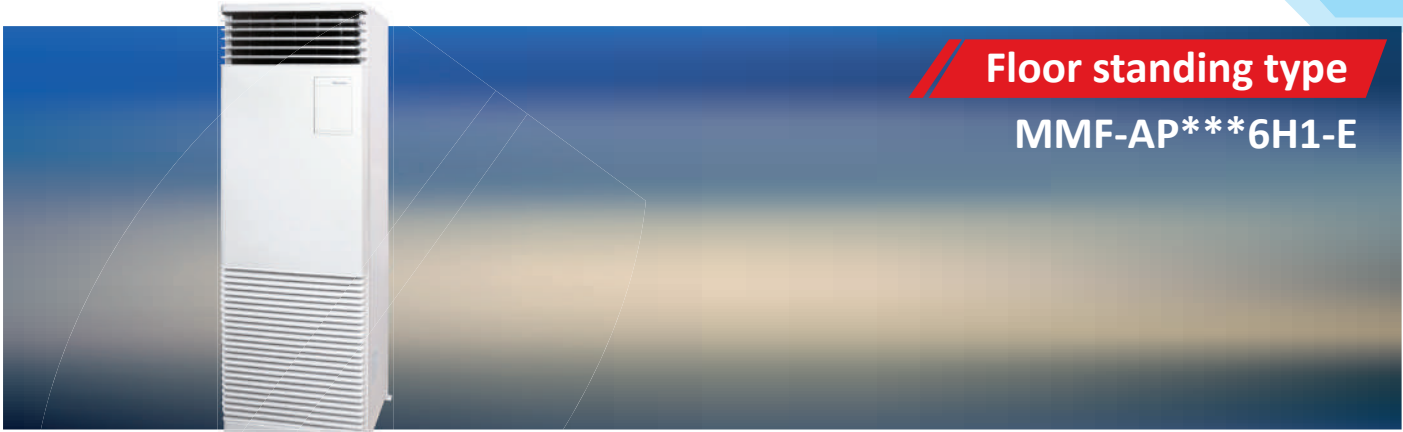

Floor standing type

MMF-AP***6H1-E

Wide outlet

Corner location is also possible, with right and left auto swing. Set the vertical angle manually.

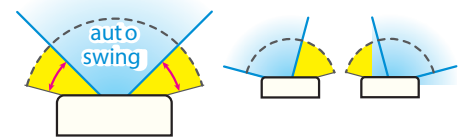

MMF-AP0156H1-E to AP0566H1-E

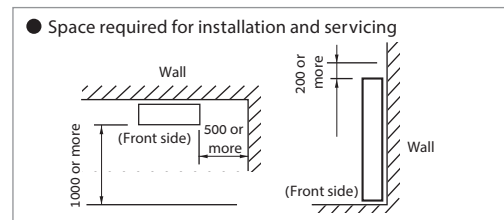
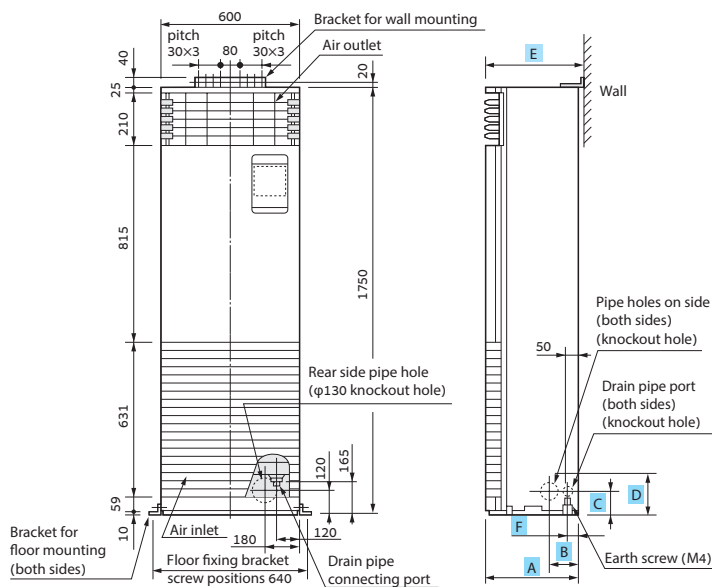

Model	MMF-	A	B	C	D	E	F
AP0156H1-E to AP0276H1-E		200	107	132	157	210	50
AP0366H1-E to AP0566H1-E		380	125	120	160	390	40

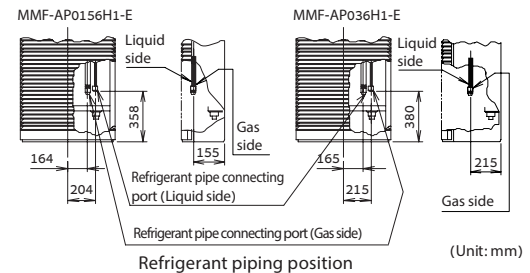

Technical specifications

Model name		MMF-	AP0156H1-E	AP0186H1-E	AP0246H1-E	AP0276H1-E	AP0366H1-E	AP0486H1-E	AP0566H1-E
Cooling/Heating capacity* ¹		(kW)	4.5/5.0	5.6/6.3	7.1/8.0	8.0/9.0	11.2/12.5	14.0/16.0	16.0/18.0
Electrical characteristics		Power requirements	1-phase 50Hz 230V (220-240V) / 1-phase 60Hz 220V (Separate power supply for indoor units required.)						
		Power consumption 50 Hz/60 Hz (kW)	0.055/0.055		0.089/0.089		0.135/0.135	0.160/0.160	
External dimensions		Height (mm)	1750						
		Width (mm)	600						
		Depth (mm)	210			390			
Total weight (kg)			46		47		62		
Fan unit		Standard air flow (High/Mid/Low) (m ³ /h)	900/780/660		1200/990/840		1920/1620/1380		2160/1730/1560
		Motor output (W)	62		62		109	109	
Connecting pipe		Gas side (mm)	ø12.7			ø12.7			
		Liquid side (mm)	ø6.4			ø9.5			
		Drain port (nominal dia.)	20 (one side of male screw)						
Sound pressure level* ² (High/Mid/Low) (dB(A))			46/42/37		49/45/39		51/46/41	54/49/44	

Note 1 : The capacities are measured under the conditions specified by JIS B 8615 based on the reference piping.

The reference piping consists of 5 m of main piping and 2.5 m of branch piping connected with 0 m height.

Note 2 : The sound level are measured in an anechoic chamber in accordance with JIS B 8616.

Normally, the values measured in the actual operating environment become larger than the indicated values due to the effects of external sound.

Note : Rated conditions Cooling : Indoor air temperature 27°C DB/19°C WB, Outdoor air temperature 35°C DB

Heating : Indoor air temperature 20°C DB, Outdoor air temperature 7°C DB/6°C WB

Large capacity floor standing duct type

MMF-AP0**4DH-V

MMF-AP1**4DH-V

Floor standing <duct type>

(50 Hz/60 Hz)

MMF-AP0724DH-V/MMF-AP0964DH-V

MMF-AP1444DH-V/MMF-AP1924DH-V

MMF-AP0724DH-V, MMF-AP0964DH-V

MMF-AP1444DH-V, MMF-AP1924DH-V

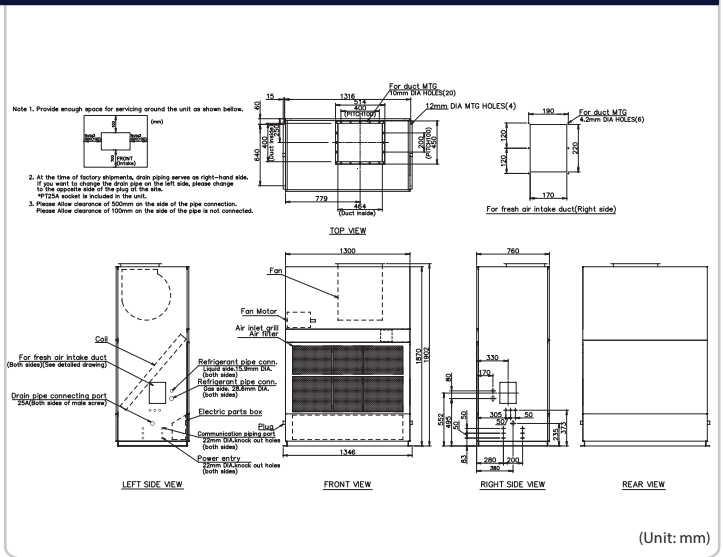
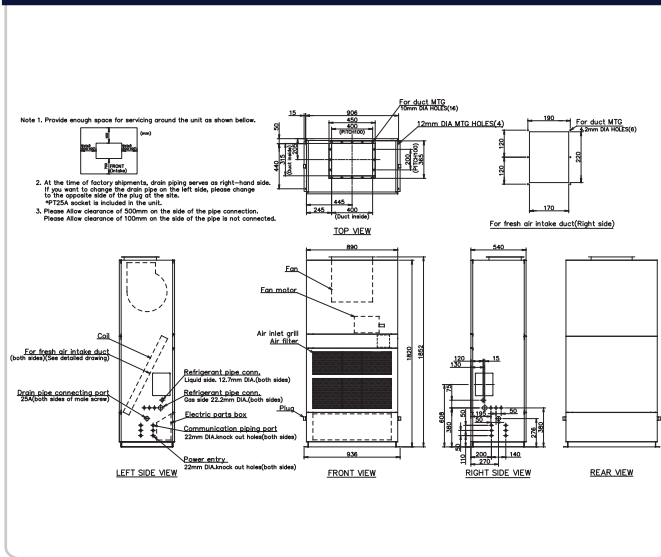

(Unit: mm)

Technical specifications

Model name	MMF-	AP0724DH-V	AP0964DH-V	AP1444DH-V	AP1924DH-V	
Cooling capacity*1	(kW)	22.4	28.0	45.0	56.0	
Electrical characteristics	Power requirements	3 phase 50/60Hz 400V(Separate power supply for indoor units is required.)				
	Power consumption 50 Hz/60 Hz	(kW)	0.59/0.70	0.80/0.99	1.04/1.28	1.79/2.26
External dimensions	Height	(mm)	1820		1870	
	Width	(mm)	890		1300	
	Depth	(mm)	540		760	
Total weight	(kg)	170	170	280	290	
Fan unit*2	Standard air flow	(m ³ /h)	3600	4200	7200	8400
	Motor output	(kW)	1.5	1.5	2.2	3.7
	External static pressure (50Hz/60Hz)	(Pa)	43/122	39/148	28/111	86/222
	Gas side	(mm)	ø22.2		ø28.6	
Connecting pipe	Liquid side	(mm)	ø12.7		ø15.9	
	Drain port	(nominal dia.)	25 (Both sides of male screw)			
Sound pressure level*3	(dB(A))	54/56	55/57	61/63	62/64	

Note 1 : The capacities and electrical characteristics are measured under the conditions specified by JIS B 8615.

Note 2 : As air volume is fixed, by remote controller, air volume cannot be changed.

When required high static pressure and air volume change, a pulley change is requested.

Note 3 : The sound level are measured in an anechoic chamber in accordance with JIS B 8616.

Normally, the sound level measured in the actual operating environment become bigger than the rated figures due to the effects of external sound.

54 Note : Rated conditions Cooling : Indoor air temperature 27°C DB/19°C WB, Outdoor air temperature 35°C DB
Heating : Indoor air temperature 20°C DB, Outdoor air temperature 7°C DB/6°C WB

Large capacity floor standing direct type

MMF-AP0**4H-VA/VB

MMF-AP1**4H-VA/VB

Floor standing <direct type>

(50 Hz)

MMF-AP0724H-VA/MMF-AP0964H-VA
MMF-AP1444H-VA/MMF-AP1924H-VA

(60 Hz)

MMF-AP0724H-VB/MMF-AP0964H-VB
MMF-AP1444H-VB/MMF-AP1924H-VB

MMF-AP0724H-VA/VB, MMF-AP0964H-VA/VB

MMF-AP1444H-VA/VB, MMF-AP1924H-VA/VB

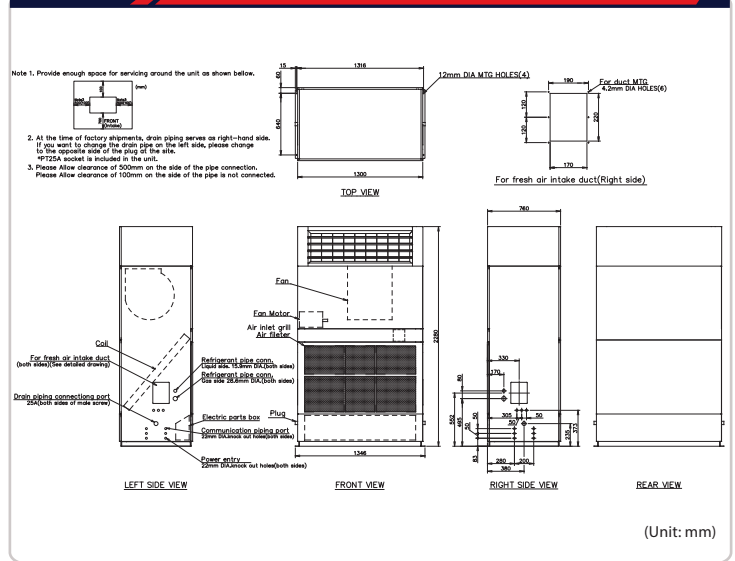
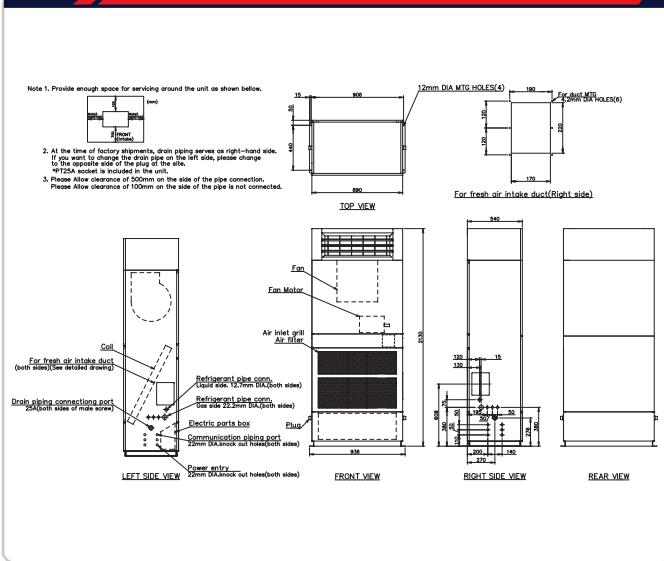

Technical specifications

Model name (50Hz/60Hz)	MMF-	AP0724H-VA/VB	AP0964H-VA/VB	AP1444H-VA/VB	AP1924H-VA/VB	
Cooling capacity*1	(kW)	22.4	28.0	45.0	56.0	
Electrical characteristics	Power requirements	3 phase 50/60Hz 400V(Separate power supply for indoor units is required.)				
	Power consumption 50 Hz/60 Hz	(kW)	0.56/0.53	0.80/0.79	1.24/1.19	2.07/2.05
External dimensions	Height	(mm)	2,130		2,280	
	Width	(mm)	890		1,300	
	Depth	(mm)	540		760	
Total weight	(kg)	182	188	320	320	
Fan unit*2	Standard air flow	(m ³ /h)	3,600	4,200	7,200	8,400
	Motor output	(kW)	0.75	1.5	22	2.2
Connecting pipe	Gas side	(mm)	ø22.2		ø28.6	
	Liquid side	(mm)	ø12.7		ø15.9	
	Drain port	(nominal dia.)	25 (Both sides of male screw)			
Sound pressure level*3	(dB(A))	62	63	64	66	

Note 1 : The capacities and electrical characteristics are measured under the conditions specified by JIS B 8615.

Note 2 : As air volume is fixed, by remote controller, air volume cannot be changed.

When required high static pressure and air volume change, a pulley change is requested.

Note 3 : The sound level are measured in an anechoic chamber in accordance with JIS B 8616.

Normally, the sound level measured in the actual operating environment become bigger than the rated figures due to the effects of external sound.

Note : Rated conditions Cooling : Indoor air temperature 27°C DB/19°C WB, Outdoor air temperature 35°C DB

Heating : Indoor air temperature 20°C DB, Outdoor air temperature 7°C DB/6°C WB



Key features

The Dx-coil interface enables the connection between third party AHU and TOSHIBA SMMS-7 with maximum capacity of the connectable AHU up to 60 HP for multiple Dx-coil (TA Control Type) interface and 20 HP for single Dx-coil (DDC) interface.

Technical specifications

Dx-coil interface type		Dx-valve kit					Dx-coil interface type		Dx-coil controller		
									TA Control Type	DDC Control Type	
Model Name		RBM-A101VAE		RBM-A201VAE			Model Name		TCB-IFDTA201E	TCB-IFDDC201E	
HP		8	10	16	18	20	Power Supply		1ph 50Hz 220V - 240V / 1ph 60 Hz 220V		
Dimension	Height (mm)	420					Dimension	Height (mm)	420		
	Width (mm)	420						Width (mm)	330		
	Depth (mm)	420						Depth (mm)	95		
Weight (kg)		3.0					Weight (kg)		3.5	4.5	

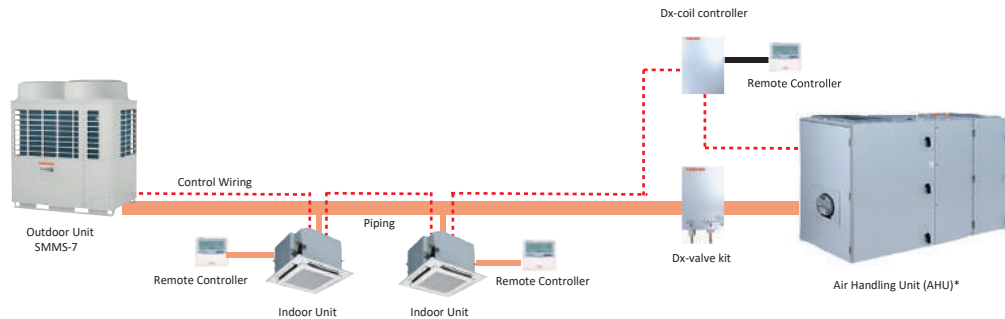

Combination

Type of DX-COIL		TA Control Type						DDC Control Type		
		Normal			Interlaced, Split face			Normal		
		Dx-coil controller	Dx-valve kit		Dx-coil controller	Dx-valve kit		Dx-coil controller	Dx-valve kit	
Model Name	TCB-IFDTA201E	RBM-A101VAE	RBM-A201VAE	TCB-IFDTA201E	RBM-A101VAE	RBM-A201VAE	TCB-IFDDC201E	RBM-A101VAE	RBM-A201VAE	
Connectable AHU Capacity	8 HP	1	1	-	-	-	1	1	-	
	10 HP	1	1	-	-	-	1	1	-	
	16 HP	1	-	1	2	2	-	1	-	
	18 HP	1	-	1	2	2	-	1	1	
	20 HP	1	-	1	2	2	-	1	1	
	32 HP	1	-	2	2	-	2	-	1	
	36 HP	1	-	2	2	-	2	-	-	
	40 HP	1	-	2	2	-	2	-	-	
	48 HP	-	-	-	3	-	3	-	-	
	54 HP	-	-	-	3	-	3	-	-	
	60 HP	-	-	-	3	-	3	-	-	

* Product image for illustration purposes only. Actual product may vary.

VRF AHU Line Up

Available Capacity



AHU Coil Type

Normal	Split Face	Interlaced	Split Row
Available Up to 40HP	Available	Available	Not Available

VRF AHU Specification

Model		39CQM0913	39CQM1015	39CQM1016
Total Cooling Capacity	kW	45.0	50.0	55.3
	HP	16	18	20
Sensible Heat	kW	35.31	33.54	37.09
Supply Air Volume (Nominated) (Min. - Max.)	CMH	7200 (5760 - 8640)	7800 (6240 - 9360)	8400 (6720 - 10080)
Fresh Air Volume	%	10	10	10
Entering Air Temperature	CDB/CWB	27.0/19.5	27.0/19.5	27.0/19.5
Leaving Air Temperature	CDB/CWB	14.6/13.9	14.3/13.6	14.3/13.6
Fresh Air Temperature	CDB/CWB	35/28	35/28	35/28
Coil Type		DX Coil R410a	DX Coil R410a	DX Coil R410a
Coil Face Area	m ²	0.75	0.91	1.14
Coil Face Velocity	m/s	2.67	2.37	2.05
Static Pressure (Nominated)	Pa	400	400	400
Fan Type		Backward Curve Centrifugal	Backward Curve Centrifugal	Backward Curve Centrifugal
Fan Model		BDB 355	BDB 400	BDB 400
Fan Motor	kW / Pole	3 / 4	3 / 4	3 / 4
Power Supply	V/PH/Hz	415/3/50	415/3/50	415/3/50
Outlet Sound Level (Nominated)	dBA	87	85	86
Condensing Unit		MMY-MAP1607T8P	MMY-MAP1807T8P	MMY-MAP2007T8P-SG
DX Coil Controller		TCB-IFDTA201E	TCB-IFDTA201E	TCB-IFDTA201E
DX-Valve Kit		RBM-A201VAE	RBM-A201VAE	RBM-A201VAE
Piping Connection	Liquid	mm	Φ15.9	Φ15.9
	Gas	mm	Φ28.6	Φ28.6
Diversity	%	60 - 110	60 - 110	60 - 110

VRF AHU Specification

Model		39CQM1317	39CQM1418	39CQM1518
Total Cooling Capacity	kW	88.0	100.8	111.9
	HP	32	36	40
Sensible Heat	kW	60.33	70.4	80
Supply Air Volume (Nominated) (Min. - Max.)	CMH	14400 (11520 - 17280)	15600 (12480 - 18720)	16800 (13440 - 20160)
Fresh Air Volume	%	10	10	10
Entering Air Temperature	CDB/CWB	27.0/19.5	27.0/19.5	27.0/19.5
Leaving Air Temperature	CDB/CWB	15.0/14.1	14.0/13.5	13.3/12.8
Fresh Air Temperature	CDB/CWB	35/28	35/28	35/28
Coil Type		DX Coil R410a	DX Coil R410a	DX Coil R410a
Coil Face Area	m ²	1.65	1.86	2.05
Coil Face Velocity	m/s	2.42	2.33	2.28
Static Pressure (Nominated)	Pa	500	500	500
Fan Type		Backward Curve Centrifugal	Backward Curve Centrifugal	Backward Curve Centrifugal
Fan Model		BDB 560	BDB 560	BDB 630
Fan Motor	kW / Pole	7.5 / 4	7.5 / 4	7.5 / 4
Power Supply	V/PH/Hz	415/3/50	415/3/50	415/3/50
Outlet Sound Level (Nominated)	dBA	85	86	86
Condensing Unit		MMY-AP3217T8P	MMY-AP3617T8P	MMY-AP4017T8P-SG
DX Coil Controller		TCB-IFDTA201E x 2	TCB-IFDTA201E x 2	TCB-IFDTA201E x 2
DX-Valve Kit		RBM-A201VAE x 2	RBM-A201VAE x 2	RBM-A201VAE x 2
Piping Connection	Liquid	mm	Φ19.1	Φ22.2
	Gas	mm	Φ34.9	Φ41.3
Diversity	%	60 - 110	60 - 110	60 - 110

Model		39CQM1521	39CQM1622	39CQM1624
Total Cooling Capacity	kW	135.0	151.2	168.0
	HP	48	54	60
Sensible Heat	kW	95	106.7	114.4
Supply Air Volume (Nominated) (Min. - Max.)	CMH	20400 (16320 - 24480)	23400 (18720 - 28080)	25200 (20160 - 30240)
Fresh Air Volume	%	10	10	10
Entering Air Temperature	CDB/CWB	27/19.5	27/19.5	27/19.5
Leaving Air Temperature	CDB/CWB	13.6/13.1	13.8/13.3	13.9/13.4
Fresh Air Temperature	CDB/CWB	35/28	35/28	35/28
Coil Type		DX Coil R410a	DX Coil R410a	DX Coil R410a
Coil Face Area	m ²	2.45	2.71	2.99
Coil Face Velocity	m/s	2.31	2.4	2.34
Static Pressure (Nominated)	Pa	500	500	500
Fan Type		Backward Curve Centrifugal	Backward Curve Centrifugal	Backward Curve Centrifugal
Fan Model		BDB 630	BDB 710	BDB 710
Fan Motor	kW / Pole	11 / 4	11 / 4	11 / 4
Power Supply	V/PH/Hz	415/3/50	415/3/50	415/3/50
Outlet Sound Level (Nominated)	dB	88	86	86
Condensing Unit		MMY-AP4817T8P	MMY-AP5417T8P	MMY-AP6017T8P
DX Coil Controller		TCB-IFDTA201E x 3	TCB-IFDTA201E x 3	TCB-IFDTA201E x 3
DX-Valve Kit		RBM-A201VAE x 3	RBM-A201VAE x 3	RBM-A201VAE x 3
Piping Connection	Liquid	mm	Φ22.2	Φ22.2
	Gas	mm	Φ41.3	Φ41.3
Diversity	%	60 - 110	60 - 110	60 - 110

Fresh air intake indoor unit type

MMD-AP***HFE



Air controller for fresh-air intake

Fresh-air intake often influences the system, rendering normal control of the air conditioner difficult, or placing large loads on the system and its cooling performance.

Therefore it is frequently adopted to handle the fresh air to a certain condition before the fresh air will enter in the main air conditioner.

This device is known as a fresh air intake indoor unit.

For some application need to get all fresh air intake connect to VRF system, SMMS-7 are available connected to 1-3 Fresh air Units up to 22 HP

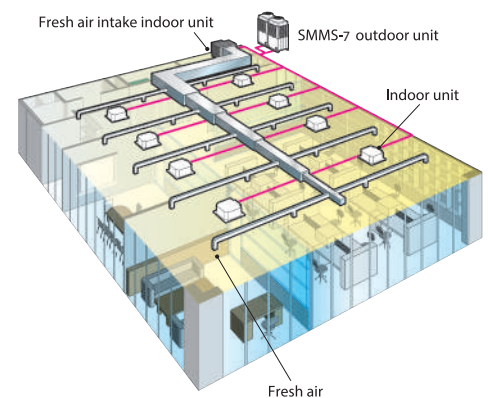

NOTE: The fresh air intake indoor unit is an air conditioner provided to handle the fresh air load and is not to control the room temperature. For correspondence to the load of the indoor air controller, set an air conditioner separately.

Technical specifications

Model name	MMD-	AP0481HFE	AP0721HFE	AP0961HFE
Cooling capacity* ¹	(kW)	14.0	22.4	28.0
Electrical characteristics	Power requirement	(kW) 1-phase 50 Hz 230 V (220-240 V)/60 Hz 220 V		
	Power consumption 50Hz/60Hz	(kW) 0.28/0.34	0.45/0.5	0.52/0.65
External dimensions	Main unit	Height	(mm) 492	
		Width	(mm) 892	1,392
		Depth	(mm) 1,262	
Total weight	(kg)	93	144	
Fan unit	Standard air flow	(m ³ /h) 1,080	1,680	2,100
	Motor output	(kW) 0.160	0.160×2	
	External static pressure 50 Hz/60 Hz	(Pa) 170-210-230 / 115-215-260	140-165-180 / 150-210-235	160-190-205 / 80-180-220
	Air flow limit Lower limit/Upper limit	(m ³ /h) 756/1,188	1,176/1,848	1,470/2,310
Connecting pipe	Gas side	(mm) ø15.9	ø22.2	
	Liquid side	(mm) ø9.5	ø12.7	
	Drain port	(mm)	25	
Sound pressure level* ² (High/Med./Low)	(dB(A))	45/43/41	46/45/44	
Operation range	Cooling* ³	(°C)	5 - 43	

* The setting temperature is 16 - 27°C (standard FCU...18 - 29°C).

* An optional humidifier is not available with fresh air intake indoor unit.

* Height difference between fresh air intake indoor units must be within 0.5 m. Height difference between fresh air intake indoor unit and standard FCU must be within 30 m.

NOTE 1 Rated conditions Cooling: Outdoor air temperature 33°C DB/28°C WB setting temperature 18°C
Heating: Outdoor air temperature 0°C DB/-2.9°C WB setting temperature 25°C
Piping: Length 7.5 m / Height 0 m

NOTE 2 Normally, the values measured in the actual operating environment become large than the indicated values due to the effects of external sound.

NOTE 3 * When supply air temperature is "setting temperature + 3°C" or less, fresh air intake indoor unit operates as FAN mode.

* When supply air temperature is 19°C or less, Fresh Air Intake Indoor unit operates as FAN mode.

Air-to-Air heat exchanger with DX-coil

MMD-VN***HEX1E/HEX1E2

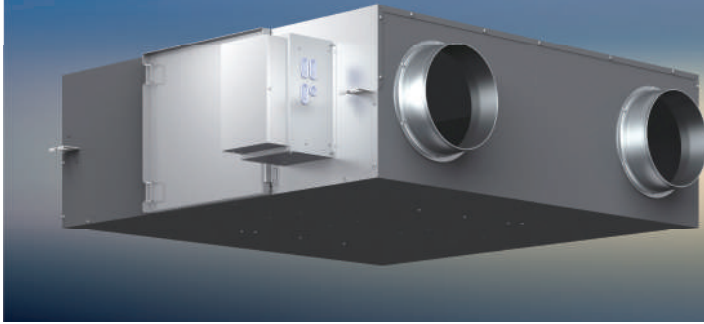

◀ **Greater comfort and reduce load**

Functionality built into the cooling system reduces load on cooling beyond that of the heat exchanger itself. This improves air quality and ensures maximum comfort throughout room being cooled.

◀ **Flexible control**

Supply and exhaust fan speed ratios can be changed for improved air volume control that best matches the needs of the environment and location.

◀ **Free cooling at night**

When the air outdoors is cooler at night, the system expels warm air from the room. This reduces the air conditioning load the next day for improved energy efficiency.



Remote controller
NRC-01HE

Technical specifications

Model name		MMD-	VN502HEX1E	VN802HEX1-E	VN1002HEX1-E	VN1002HEX1E2	
Fresh air conditioning load	Cooling (*1)	(kW)	4.10 (1.30)	6.56 (2.06)	8.25 (2.32)	8.25 (2.32)	
	Power supply		1-phase 50Hz 230V (220-240V) / 1-phase 60Hz 220V (Separate power supply for indoor units required.)		1-phase 50Hz 230V (220V-240V) (Separate power supply for indoor units is required.)	1-phase 60Hz 220V (Separate power supply for indoor units is required.)	
Temperature exchange efficiency 50Hz / 60Hz	High	(%)	70.5/70.5	70.0/70.0	65.5		
	Mid	(%)	70.5/70.5	70.0/70.0	65.5		
	Low	(%)	71.5/72.0	72.5/73.0	67.5	68.0	
Enthalpy exchange efficiency 50Hz / 60Hz	Cooling	High	(%)	56.5/56.5	56.0/56.0	52.0	
		Mid	(%)	56.5/56.5	56.0/56.0	52.0	
		Low	(%)	57.5/58.0	59.0/59.	54.0	5.0
Fan unit 50Hz / 60Hz	Standard air flow	High	(m ³ /h)	500/500	800/800	950	
		Mid	(m ³ /h)	500/500	800/800	950	
		Low	(m ³ /h)	440/410	640/600	820	800
	External static pressure	High	(Pa)	120/200	120/190	135	195
		Mid	(Pa)	105/170	100/155	120	160
		Low	(Pa)	115/150	100/130	105	130
Sound pressure 50Hz / 60Hz	High	(dB)	37.5/40.0	41.0/43.0	43.0	43.5	
	Mid	(dB)	36.5/38.0	40.0/42.0	42.0		
	Low	(dB)	34.5/36.5	38.0/37.0	40.0		
External Dimensions	Height	(mm)	430				
	Width	(mm)	1140	1189			
	Depth	(mm)	1690	1739			
Total weight		(kg)	84	100	101	103	
Connecting piping	Gas side	(mm)	ø9.5				
	Liquid side	(mm)	ø6.4				
Drain port		(Nominal dia .mm)	25(Polyvinyl chloride tube)				

(*1) Cooling and heating capacities are based on the following conditions:
 Cooling capacities are based on : indoor temperature :27 °CDB/19°CWB, Outdoor temperature : 35°CDB
 Heating capacities are based on : indoor temperature :20 °CDB, Outdoor temperature : 7 °CDB/6°CWB
 Fan is based on High and Middle
 () : The figures in () indicate the heat reclaimed from the heat recovery ventilator.

*If high humidity air (about 80% or more of relative humidity), such as fog, is inhaled by the Heat Exchanger, dew condensation water may trickle from a main body.

MMD-VN502HEX1E

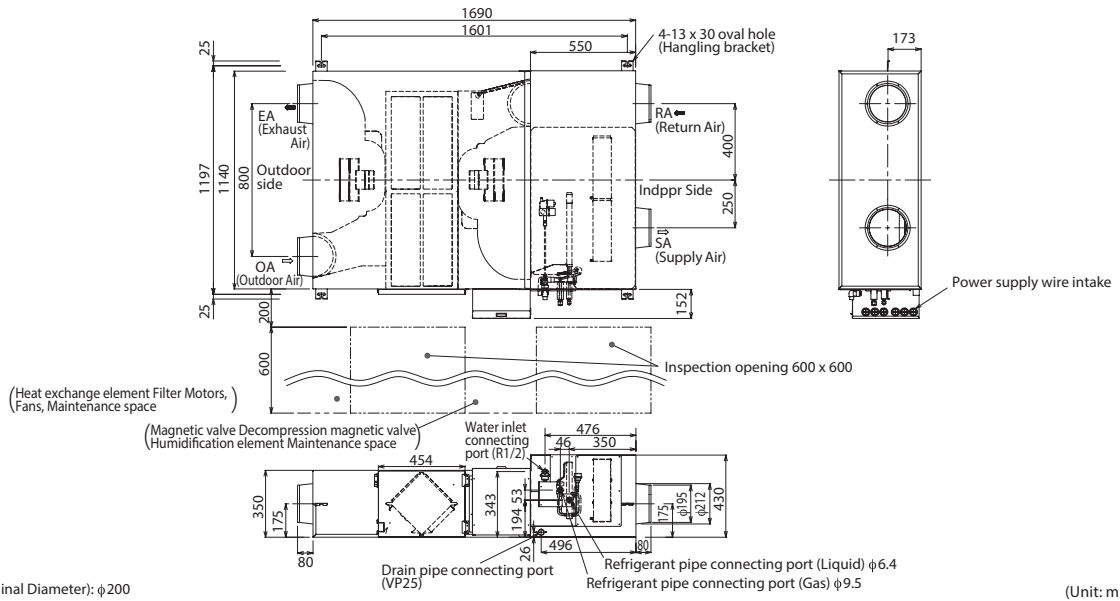

MMD VN802HEX1E to VN1002HEX1E/2

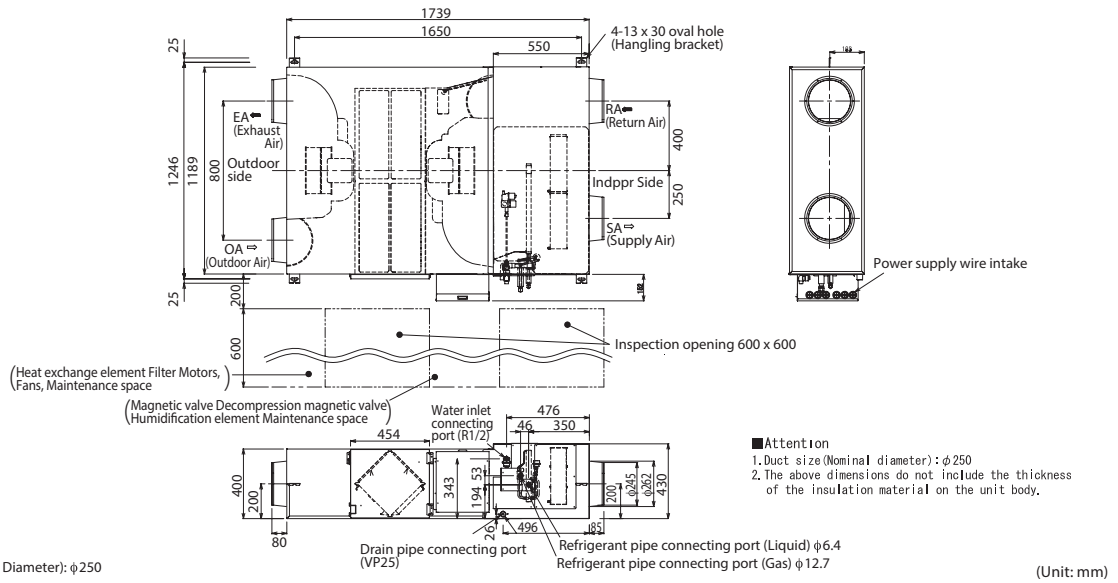

Options

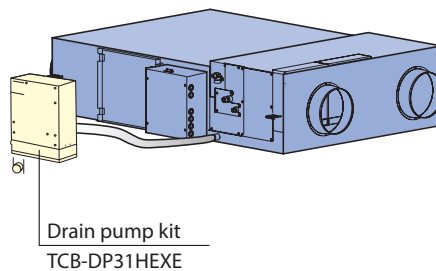

Air-to-Air heat exchanger (Stand alone unit)

VN-M*HE**

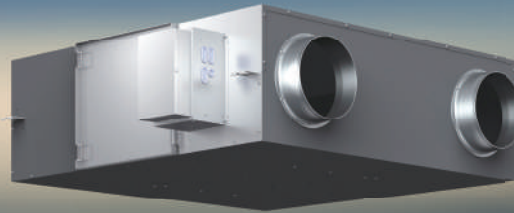

- Greater comfort and reduced load**
Easily integrated into air conditioning systems of 150 m³/h to 2000 m³/h air volume, the air-to-air heat exchangers use exhaust air to pre-condition the incoming air, thus reducing the cooling or heating load and the overall size of the required system.
- Flexible control**
Supply and exhaust fan speed ratios can be changed for improved air volume control that best matches the needs of the environment and location.

- Free cooling at night**
When the air outdoor is cooler at night, the system expels warm air from the room. This reduces the air conditioning load the next day for improved energy efficiency.

- Easy maintenance**
The heat exchange element can be washed in water.



Remote controller
NRC-01HE

* Do not connect to refrigerant piping from outdoor unit. Control wires can be connected.

Model name		VN-	M150HE	M250HE	M350HE	M500HE	M650HE	M800HE	M1000HE	M1500HE	M2000HE
Power supply (V)	Fan speed	1-phase 50Hz 230V (220-240V) / 1-phase 60Hz 220V (Separate power supply for indoor units required.)									
Power consumption 50Hz/60Hz (W)	(Extra high)	68-78/76	123-138/131	165-182/209	214-238/260	262-290/307	360-383/446	532-569/622	751-786/928	1084-1154/1294	
	High	59-67/65	99-111/105	135-145/162	176-192/206	240-258/283	339-353/408	494-538/589	708-784/830	1032-1080/1220	
	Low	42-47/45	52-59/54	82-88/94	128-142/144	178-191/206	286-300/333	353-370/411	570-607/660	702-742/818	
Air volume (m ³ /h)	(Extra high)	150/150	250/250	350/350	500/500	650/650	800/800	1000/1000	1500/1500	2000/2000	
	High	150/150	250/250	350/350	500/500	650/650	800/800	1000/1000	1500/1500	2000/2000	
	Low	110/110	155/155	210/210	390/390	520/520	700/700	755/755	1200/1200	1400/1400	
External static pressure (Pa)	(Extra high)	82-102/99	80-98/97	114-125/167	134-150/181	91-107/134	142-158/171	130-150/185	135-156/165	124-143/165	
	High	52-78/59	34-65/38	56-83/33	69-99/63	58-82/68	102-132/102	97-122/120	103-129/108	92-116/102	
	Low	47-64/46	28-40/22	65-94/39	62-92/44	61-96/52	76-112/58	84-127/55	112-142/109	110-143/87	
Sound pressure level (dB(A))	(Extra high)	26-28/27.5	29.5-30/31.5	34-35/35.5	32.5-34/33.5	34-36/35.5	37-38.5/38	39.5-40.5/41.5	38-39/39.5	41-42.5/42.5	
	High	24-25.5/24.5	25-27/25	30-32/29.5	29.5-31/29	33-34/34	35.5-37/35	38.5-40/39	36.5-37.5/36.5	39.5-41/40	
	Low	20-22/20	21-22/21	27-29/23.5	26-29/24.5	31-32.5/29.5	33.5-35/32.5	34-35.5/33.5	36-37.5/35.5	37-38/36.5	
Temperature exchange efficiency (%)	(Extra high)	81.5/81.5	78/78	74.5/74.5	76.5/76.5	75/75	76.5/76.5	73.5/73.5	76.5/76.5	73.5/73.5	
	High	81.5/81.5	78/78	74.5/74.5	76.5/76.5	75/75	76.5/76.5	73.5/73.5	76.5/76.5	73.5/73.5	
	Low	83/83	81.5/81.5	79.5/79.5	78/78	76.5/76.5	77.5/77.5	77/77	79/79	77.5/77.5	
Enthalpy exchange efficiency (%)	for cooling	(Extra high)	69.5/69.5	65/65	60.5/60.5	64.5/64.5	61.5/61.5	64/64	60.5/60.5	64/64	60.5/60.5
		High	69.5/69.5	65/65	60.5/60.5	64.5/64.5	61.5/61.5	64/64	60.5/60.5	64/64	60.5/60.5
		Low	71/71	69/69	67/67	66.5/66.5	64/64	65.5/65.5	64.5/64.5	67/67	65.5/65.5
Dimensions (Length x Width x Height) (mm)		900 x 900 x 290			1140 x 1140 x 350		1189 x 1189 x 400		1189 x 1189 x 810		
Weight (kg)		36		38		53		70		143	
Duct diameter (mm)		100		150		200		250		inside: 250, outside: 283 x 730	
Operating range	Around unit	-10°C - 40°C 80% RH or less									
	Outdoor Air (OA)	-15°C (*1) - 43°C RH									
	Return Air (RA)	5°C - 40°C 0% RH or less									

* Air volume can be changed over to high (extra high) mode or low mode.
 * Sound pressure level is measured 1.5m below the center of the unit.
 * Sound pressure level is the value which was measured at the acoustic room.
 * The actual values in an external operating environment are generally higher than the indicated values due to the contribution from ambient noise.
 * Sound pressure level is less than 70 dBA

*If high humidity air (about 80% or more of relative humidity), such as fog, is inhaled by the Heat Exchanger, dew condensation water may trickle from a main body.

VN-M150HE to VN-M350HE

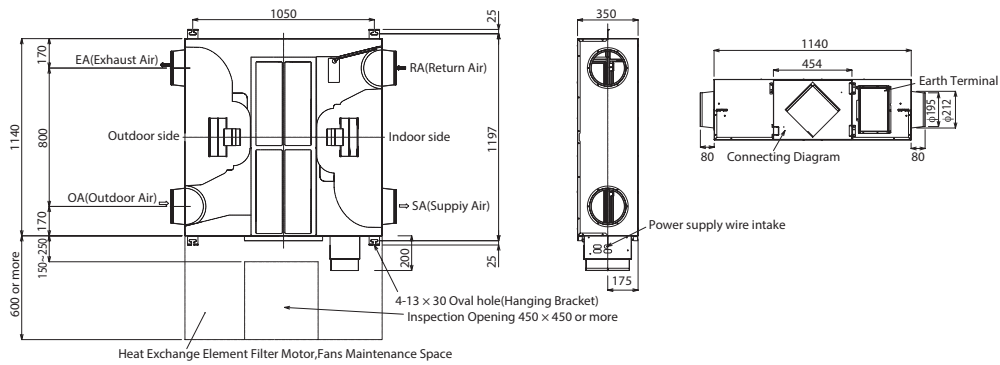

Duct size (Nominal Diameter): $\phi 200$

(Unit: mm)

VN-M500HE, VN-M650HE

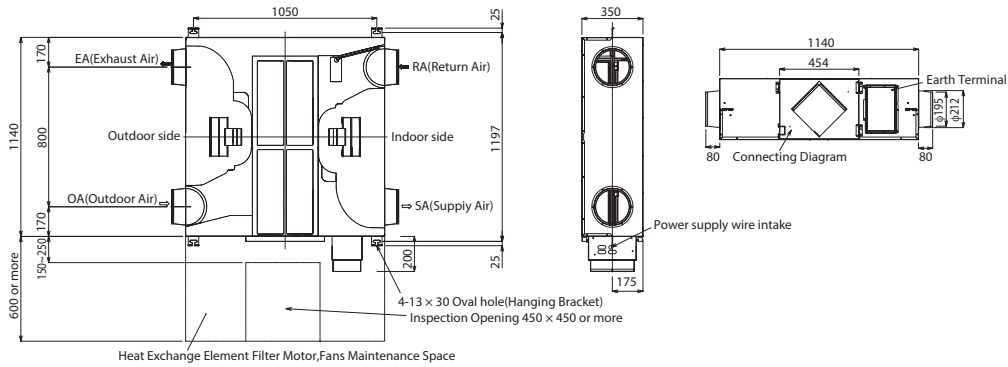

Duct size (Nominal Diameter): $\phi 200$

(Unit: mm)

VN-M800HE, VN-M1000HE

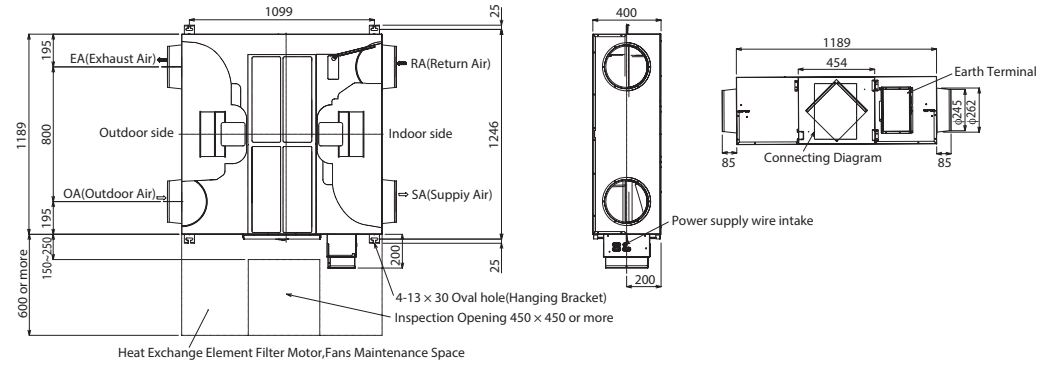

Duct size (Nominal Diameter): $\phi 250$

(Unit: mm)

VN-M1500HE, VN-M2000HE

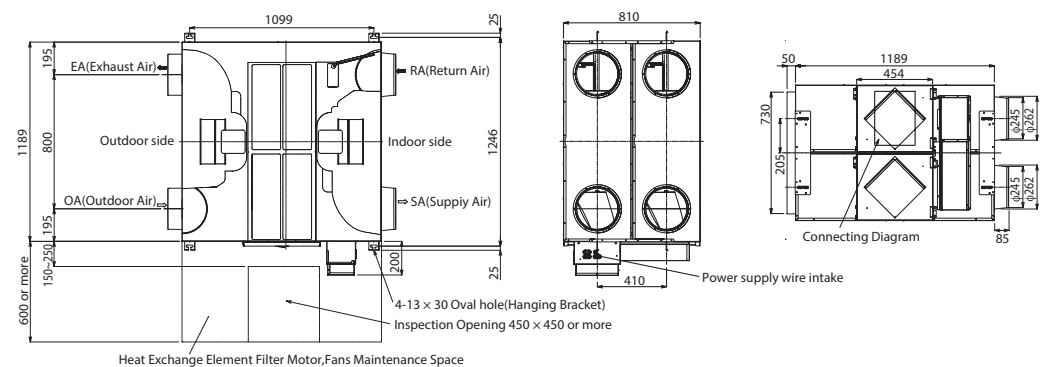

Duct size (Nominal Diameter): $\phi 250$

(Unit: mm)

Indoor unit accessories

Indoor unit	Parts Name	Model Name	Applied Model	Notes	Remarks
4-way air discharge cassette type	Ceiling panel	RBC-U31PG(W)-E	MMU-AP***4HP1-E	Required accessory	
	Fresh air inlet box	TCB-GB1602UE		For fresh air intake by using the knockout hole of fresh air filter chamber. (dia.=100 mm)	Use with TCB-GFC1602UE
	Fresh air filter chamber	TCB-GFC1602UE		For fresh air inlet box	
	Auxiliary fresh air flange	TCB-FF101URE2		For easy fresh air intake by using the knockout hole of indoor unit. (dia.=100 mm)	
	Spacer for height	TCB-SP1602UE		Height=50 mm	
	Air discharge direction kit	TCB-BC1602UE		Air direction charge by cutting off air discharge port (3 pcs.)	
Compact 4-way cassette type	Ceiling panel	RBC-UM21PG(W)-E	MMU-AP***7MH-E	Required accessory	
	Auxiliary fresh air flange	TCB-FF101URE2		For easy fresh air intake by using the knockout hole of indoor unit. (dia.=100 mm)	
	Occupancy sensor	TCB-SIR41UM-E			
2-way air discharge cassette type	Ceiling panel	RBC-UW283PG(W)-E RBC-UW803PG(W)-E RBC-UW1403PG(W)-E	MMU-AP0072 to 0152WH1 MMU-AP0182 to 0302WH1 MMU-AP0362/0482/0562WH1	Required accessory	
	Super long life filter	TCB-LF283UW-E	MMU-AP0072 to 0152WH1	Dust collecting effect: 50% (Weight method)	Use with TCB-FC283UW-E
		TCB-LF803UW-E	MMU-AP0182 to 0302WH1		Use with TCB-FC803UW-E
		TCB-LF1403UW-E	MMU-AP0362/0482/0562WH1		Use with TCB-FC1403UW-E
	Filter chamber	TCB-FC283UW-E	MMU-AP0072 to 0152WH1	For super long life filter	
		TCB-FC803UW-E	MMU-AP0182 to 0302WH1		
	Auxiliary fresh air flange	TCB-FC1403UW-E	MMU-AP0362/0482/0562WH1		
1-way air discharge cassette type	Ceiling panel	RBC-UW283PG(W)-E	MMU-AP0072 to 0152WH1	Required accessory	
	Front air discharge unit	RBC-US21PGE TCB-BUS21HWE	MMU-AP***4SH1-E	Required accessory	
	Auxiliary fresh air flange	TCB-FF101URE2		For easy fresh air intake by using the knockout hole of indoor unit. (dia.=100 mm)	
Slim duct type	Auxiliary fresh air flange	TCB-FF101URE2	MMD-AP***4SPH1-E	For fresh air intake by using the knockout hole of indoor unit. (dia.=100)	
Concealed duct type	Spigot shaped flange	TCB-SF56C6BPE	MMD-AP0076 to 0186BHP1-E		
		TCB-SF80C6BPE	MMD-AP0246/0276/0306BHP1-E		
		TCB-SF160C6BPE	MMD-AP0366/0486/0566BHP1-E		
Concealed duct high static pressure type	Long Life Filter Kit	TCB-LK801D-E	MMD-AP0186/0246/0276HP1-E		
		TCB-LK1401D-E	MMD-AP0366/0486/0586HP1-E		
	Auxiliary fresh air flange	TCB-FF151US-E	MMD-AP***6HP1-E		
	Long life filter kit	TCB-LK2801DP-E	MMD-AP0726/0966HP-E	Flange shaped, Mount chassis directly, Upside down mountable	
Drain pump kit	TCB-DP40DPE	MMD-AP0726/0966HP-E	Lift up 500 mm		
Ceiling type	Drain pump kit	TCB-DP31CE	MMC-AP0158/0188HP-E MMC-AP0248 to 0568HP-E	Stand-up 600 or less (from bottom face of ceiling)	Use with TCB-KP13CE Use with TCB-KP23CE
		TCB-KP13CE TCB-KP23CE	MMC-AP0158/0188HP-E MMC-AP0248 to 0568HP-E	Needed when drain pump kit is used	
	Elbow piping kit	TCB-KP13CE TCB-KP23CE	MMC-AP0158/0188HP-E MMC-AP0248 to 0568HP-E		
Air to Air Heat Exchanger with DX-coil	Drain pump kit	TCB-DP31HEXE	MMD-VN502 to 1002HEX1E	Stand-up 330 mm or less (from bottom face of ceiling)	
Fresh air intake indoor unit type	High-efficiency filter 65	TCB-UFM3DE	MMD-AP0721/0961HFE	Dust collecting effect: 65% (NBS Colorimetric method)	Use with TCB-PF3DE
		TCB-UFM4D-1E	MMD-AP0481HFE		Use with TCB-PF4D-1E
	High-efficiency filter 90	TCB-UFH7DE	MMD-AP0721/0961HFE	Dust collecting effect: 90% (NBS Colorimetric method)	Use with TCB-PF3DE
		TCB-UFH8D-1E	MMD-AP0481HFE		Use with TCB-PF4D-1E
	Long life prefilter	TCB-PF3DE	MMD-AP0721/0961HFE	Dust collecting effect: 50% (Weight method)	
		TCB-PF4D-1E	MMD-AP0481HFE		
	Filter chamber	TCB-FCY51DFE	MMD-AP0481HFE	For high-efficiency filter or long life prefilter	
Drain pump kit	TCB-FCY100DE	MMD-AP0721/0961HFE			
	Drain pump kit	Drain pump kit	MMD-AP0481HFE/0721/0961HFE	Stand-up 330 or less (from bottom face of ceiling)	

		Combination Pattern					
		1	2	3	4	5	6
1) Accessory for 4-way air discharge cassette type: combination pattern		Ceiling panel	Fresh air inlet box + Fresh air filter chamber	Fresh air filter chamber	Auxiliary fresh air flange	Space for height adjustment	Air discharge direction kit
1	Ceiling panel		OK	OK	OK	OK	OK
2	Fresh air inlet box + Fresh air filter chamber	OK			OK	—	OK
3	Fresh air filter chamber	OK			OK	OK	OK
4	Auxiliary fresh airflange	OK	OK	OK		OK	OK
5	Spacer for height adjustment	OK	—	OK	OK		OK
6	Air discharge direction kit	OK	OK	OK	OK	OK	



Remote controllers

Air-conditioning Management System on site

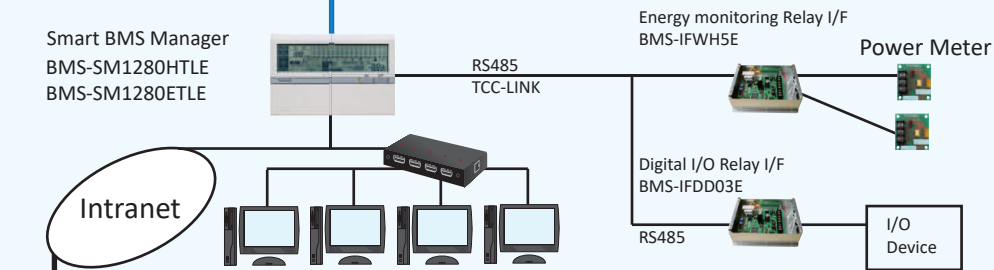
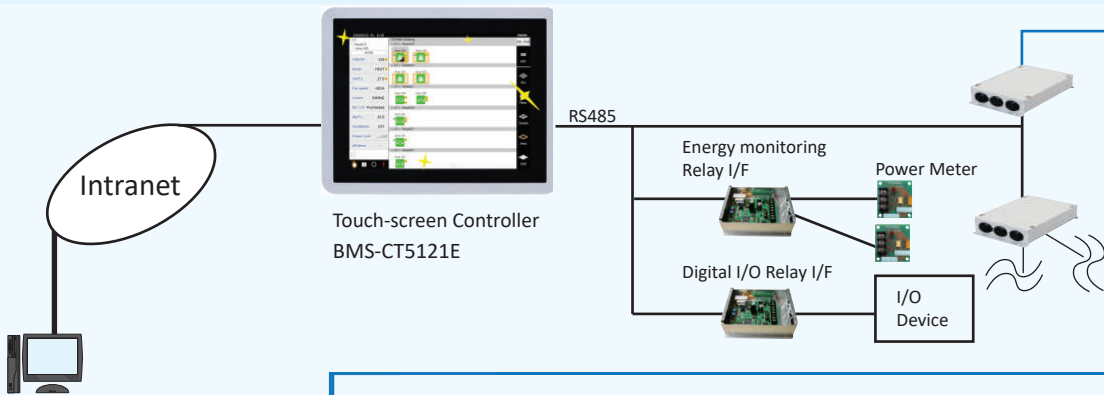
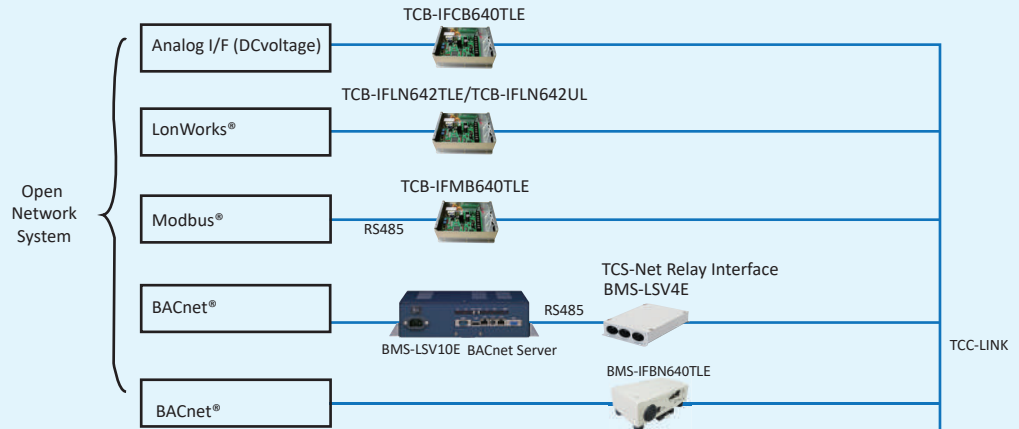

Central Remote Controller



ON-OFF controller
TCB-CC163TLE2



Schedule timer
TCB-EXS21TLE



Central remote controller
BMS-CM1280TLE

1. LonWorks® : Registered trademark by Echelon corporation.
2. BACnet® : ANSI/ASHRAE 135-1995, A data Communication Protocol for Building Automation and Control Network.
3. Modbus® : Registered trademark by Schneider E.

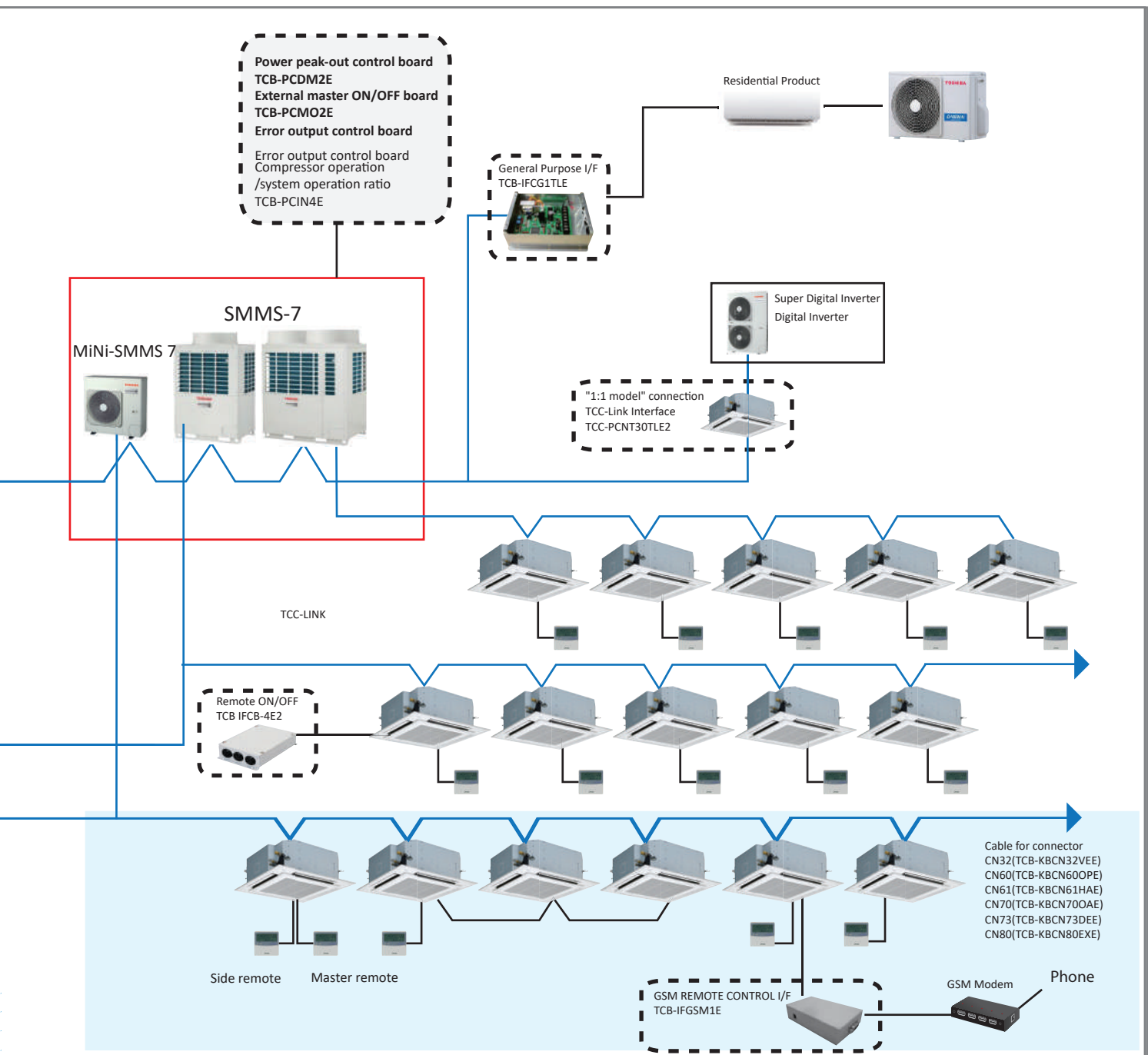

Wire remote controller/Wireless remote controller

<p>Wired remote Controller RBC-AMS55E-ES RBC-AMS55E-EN</p>	<p>Wired remote controller with Weekly timer RBC-AMS41E</p>	<p>Wired remote controller RBC-AMT32E</p>	<p>Simple remote controller RBC-AS41E2</p>	<p>Wireless remote controller</p>	<p>Remote Sensor TCB-TC411E</p>

Wired remote controller



Wired Remote Controller
RBC-AMS55E-ES
RBC-AMS55E-EN

Wired remote controller with a built in 7-day timer-featuring a new multi-language, LCD display with backlight, energy saving options and a return back function.

- Possibility to set and display the room name to easily set-up and monitor the working parameter.
- New modern and desirable controller design with menu driven display.
- Save mode by schedule timer to optimise energy consumption.
- Room temperature display always available.
- Two "Hot Keys" (F1, F2) for easy operation of air conditioner functions.
- Easy to read layout including display of indoor unit model name and serial number.
- Built-in backup power. Settings are kept in memory up to 72 hours in case of power failure.
- Remote TA sensor available in controller.
- Can be connected to a single indoor unit or a group of up to 8 indoor units.



Standard Remote controller
RBC-AMT32E

Standard wired remote controller can be connected to a single indoor unit or a group of up to 8 indoor units.

Power save operation limits the greatest current value. The remote controller allows error to be displayed while the protective device works or a error occurs.



Remote controller with weekly timer
(7-day timer function)
RBC-AMS41E

- Clock display
 - Schedule timer: Possible to program schedule timer (7-day timer) function
Possible to program 8 functions for each day of the week
- * The following items can be set in program:
operation time,
operation start/stop, operation mode,
temperature setting,
restriction on button operation



Wired Remote Controller
RBC-ASC11E

- Compact size H86mm x W86mm x D16mm
- Stylish design with big screen and backlight
- Schedule timer (off only)
- Operation mode, error code display
- Temperature control in steps of 0.5°C

Wireless remote controller



Wireless remote controller kit & sensor unit
(receiver unit)

- Start/Stop • Changing mode • Temperature setting
- Air flow changing
- Timer function
Either "ON" time or "OFF" time or "CYCLIC" can be set how many 30 min. later ON or OFF is operated.
- Control by 2 remote controllers is available.
Two wireless remote controllers can operate one indoor unit. The indoor unit can then be operated separately from the two different locations.
- Check code display

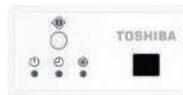

RBC-AX33CE
Integral receiver
(For ceiling) (MMC-AP**8HP-E)
(MMU-AP***4SH1-E)



TCB-AX32E2
Stand alone receiver
(For 4-way air discharge cassette,
compact 4-way cassette,
2-way air discharge cassette,
ceiling, concealed duct standard,
slim duct, floor standing cabinet,
floor standing, 1-way discharge cassette
(MMU-AP***4YH1/SH1-E)



RBC-AX32U(W)-E
RBC-AX32U(W)-E
Integral receiver (MMU-AP***4HP1-E)
(For 4-way air discharge cassette)



RBC-AX32UW(W)-E
Integral receiver (MMU-AP***2WH1)
(For 2-way air discharge cassette)



RBC-AX32UM(W)-E
Integral receiver
(MMU-AP***7MH-E)
(For compact 4-way
discharge cassette)

Central remote controller



Central remote controller
TCB-SC643TLE

- Overview
 - Compact size 120mmx120mm with 3.2 inch display
 - Touch button with stylish design
 - Multi languages (English, Chinese, French, Spanish)
 - Simple one touch All On/Off function
 - Multiple display mode (All, Zone, Unit) to control and monitor
- Operation
 - Individual operation of 64 indoor units available
 - Weekly Schedule Operation* (ON/OFF) * Schedule timer necessary
- Monitoring
 - Zone setting (up to 10 zones)
 - Alarm display



Schedule timer
TCB-EXS21TLE

- Schedule timer
 - 6 programmings per day
 - Enabling 8 groups to be programmed
 - A maximum of 64 indoor units can be controlled
 - A maximum of 100 hours back-up power supply
 - Weekly timer mode
 - 7 types of weekly schedule and 3 programmings per day

Other



Remote sensor
TCB-TC41LE

Install this sensor when outside air has been introduced or when over cooling are being minimised.



Wired remote controller for air to air heat exchanger
NRC-01HE

- Up to 8 units of the Air to Air Heat Exchanger can be operated using this remote controller.
- Control by 2 remote controllers is available. Two remote controllers can operate a single Air to Air Heat Exchanger.
- Air conditioning units may be controlled in addition to controlling the Air to Air Heat Exchanger.
- Central control allows linked ON/OFF operation of air conditioner and Air to Air Heat Exchanger.
- Central control can be set to allow standalone operation of the Air to Air Heat Exchanger.
- Switchable ventilation modes (Automatic/Air to Air/Normal)
- Switchable ventilation air volume (Extra-high/High-Low)

Building management systems

SMART BMS MANAGER / SMART BMS MANAGER WITH DATA ANALYSER

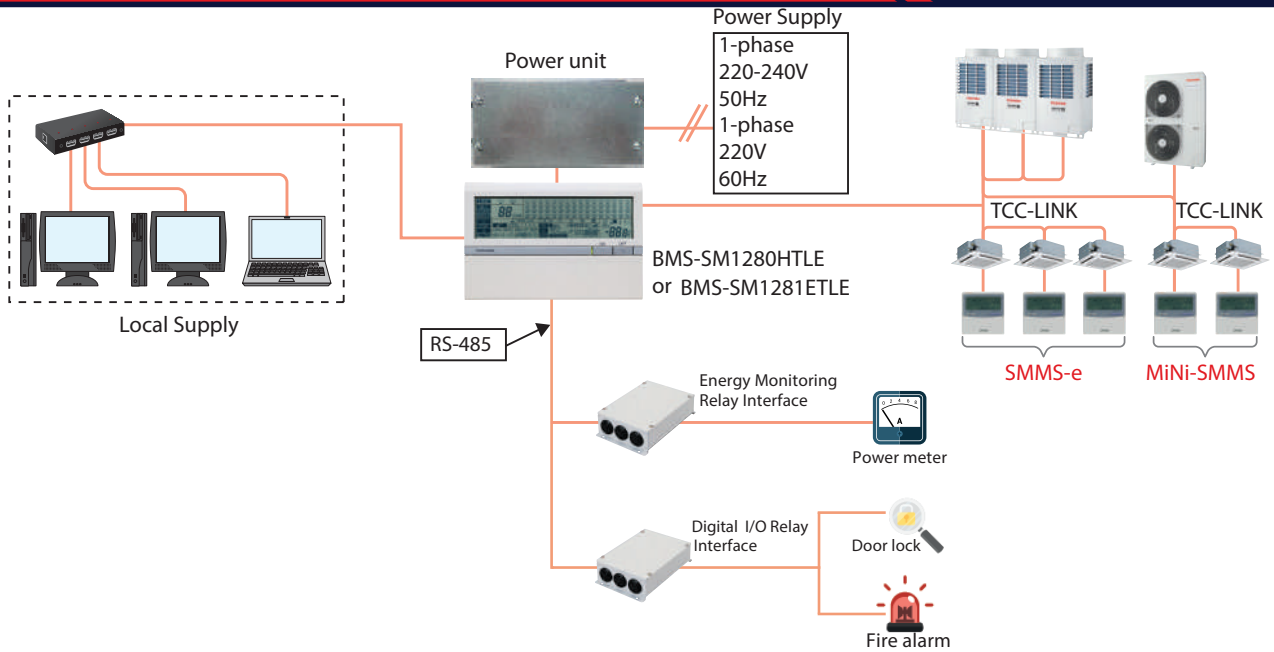

Touch screen controller

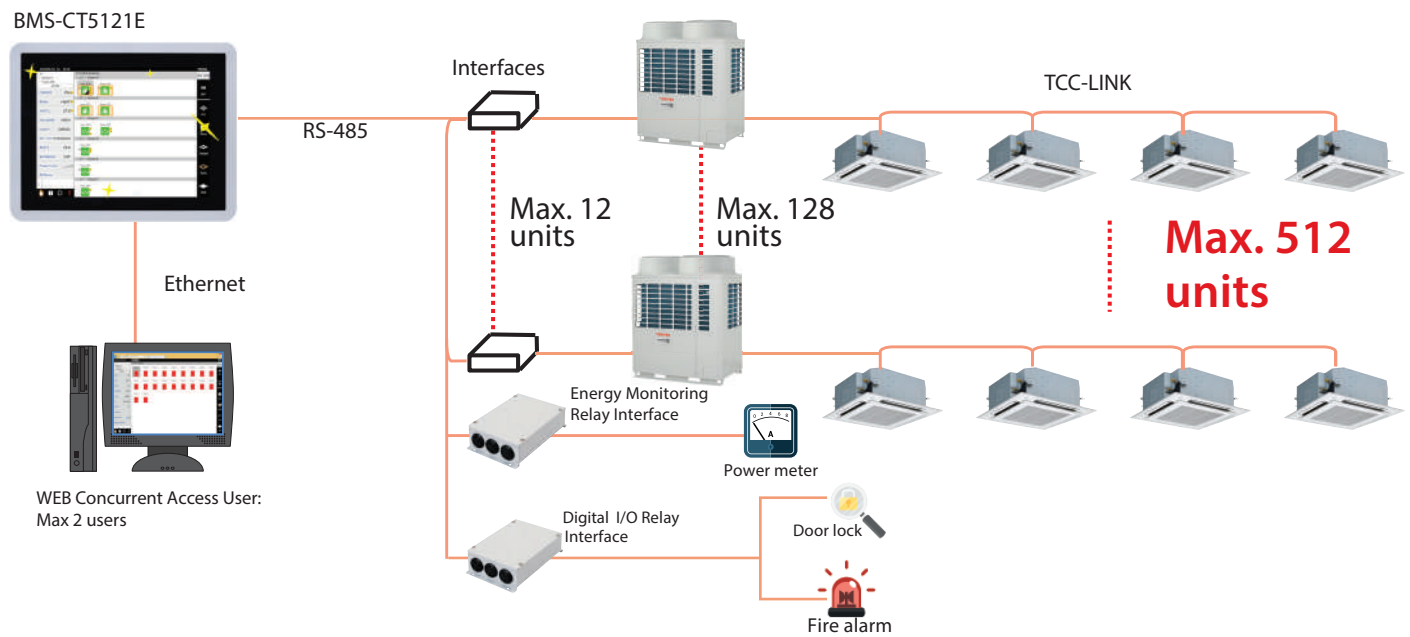
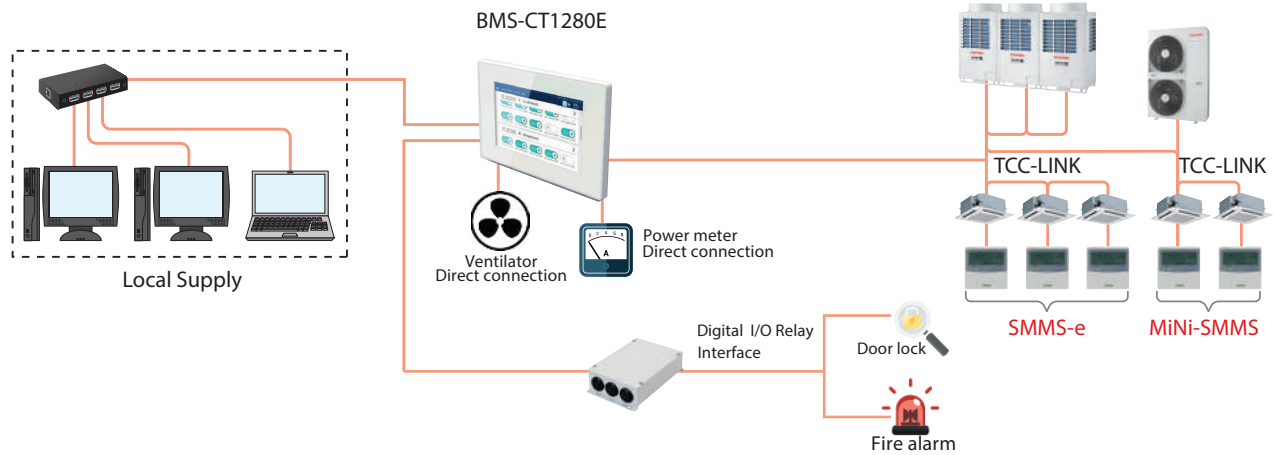

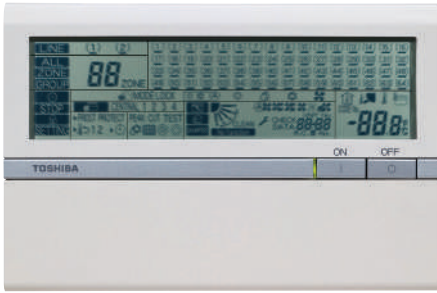

SMART BMS MANAGER
BMS-SM1280HTLE

Web browser control software

- List View available - Displays all Indoor units in one screen
- Set View available - how basic Indoor unit settings on main screen
- Advanced operation and master schedules functions available
- Advanced operation and master schedules can be set on a calendar
- Up to 4 concurrent users can be connected
- Up to 32 user accounts can be programmed with different levels of access (at least 1 must be administrator level)
- Energy monitoring and billing functions are available. Power meter locally supplied energy.
- Additional digital I/O device is available
- Thin profile controller and separate power supply unit enables easy installation.

TOUCH SCREEN CONTROLLER
BMS-CT1280E



SMART SLIDE SWITCH

Individual



won iF DESIGN AWARD 2019, with intuitive control via slide switch icons and meter dashboard.

Features

- Easy control and user friendly interface on the touch screen controller.
- Attractive UI and multiple display design for Business (Office/shop) and Residential use.
- Compact size 136mmx205mm with 7 inch colour display
- Simple one touch All On/Off function
- Simple monitoring for multiple indoor units monitoring and control without PC (up to 128 IDUs)
- Direct DI/DO or Power meter I/P without relay interface.
- Weekly schedule setting and special days setting.

SMART MANAGER WITH DATA ANALYSER
BMS-SM1281ETLE



Energy monitoring display

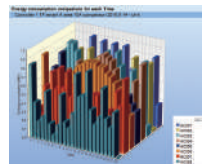

3D energy view

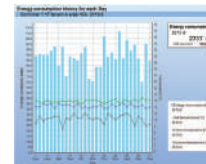

Daily energy view



TOUCH SCREEN CONTROLLER
BMS-CT5121E

- Touch screen controller
- Using the touch screen controller provides a clear display and enables easy operation. A maximum of 512 units / groups are controllable.
- Energy monitoring and billing application
- Power meter locally supplied Energy
- Web connection
- Layout diagram function (Option)

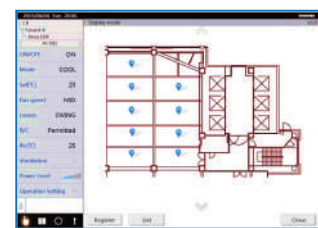

LAYOUT DIAGRAM FUNCTION
(OPTION)

FEATURES

- Icon display
- Return back function
- Save & demand control for outdoor unit
- Ventilation unit control & monitoring
- Setting temp. range control
- Setting temp. shift
- Layout diagram function (Option)



Relay Interface BMS-IFWH5E
For Energy Monitoring to connect power meter
Relay Interface BMS-IFDD03E
Fto connect external digital input/output



Relay Interface BMS-IFLSV4E
For TCS-NET (Max. 64 FCU/Unit)

Open network systems

BACnet® system

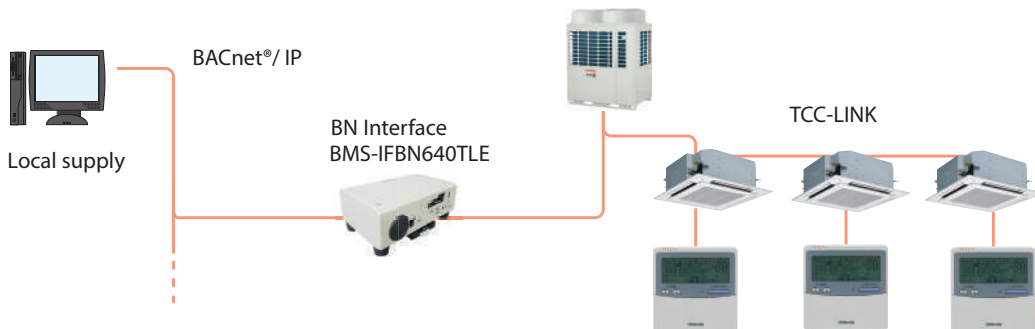

LonWorks®

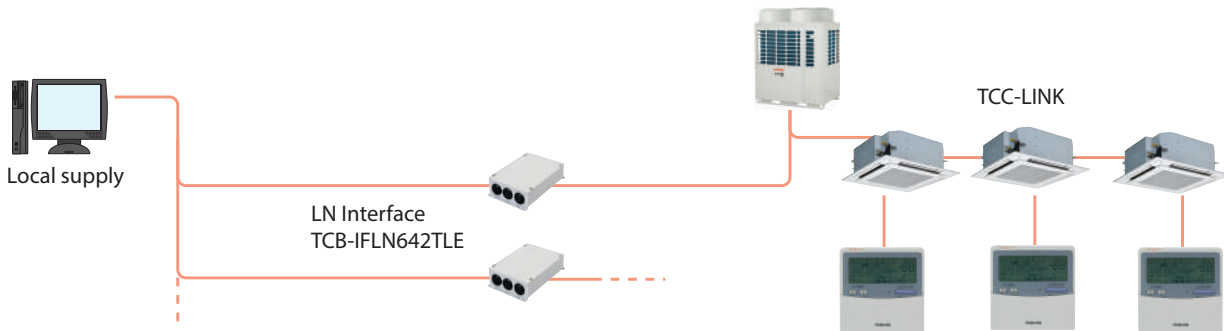

Modbus®

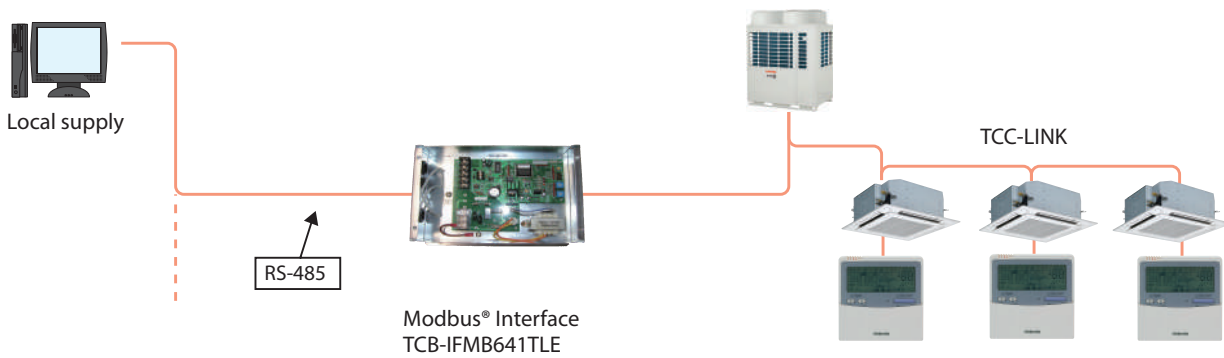



Intelligent Server
BMS-LSV9E



BACnet® Server Software
BMS-STBN10E



Relay Interface BMS-IFLSV4E
For TCS-NET

• **BACnet®**

The BACnet® system operates in conjunction with the BACnet®. Server uses object signals to provide the following functions:

• **Control**

- ON/OFF
- Temperature setting
- Fan speed
- Max. 128 FCU

• **Monitoring**

- ON/OFF
- Operation mode
- Temperature setting
- Room temperature
- Local remote controller : permit / prohibit



BN Interface
BMS-IFBN640TLE

• **BACnet®**

The BACnet® system operates in conjunction with the BACnet®. Server uses object signals to provide the following functions:

• **Control**

- ON/OFF
- Temperature setting
- Fan speed
- Max 64 FCU

• **Monitoring**

- ON/OFF
- Operation mode
- Temperature setting
- Room temperature
- Local remote controller : permit / prohibit



LN Interface
TCB-IFLN642TLE

• **LonWorks® LN Interface**

The LonWorks® interface manages the SMMS-e air conditioning system as a Lon device to communicate with the customer's Building Management System and to monitor operational status.

A maximum of 64 units / groups are controllable per interface.

• **SNVT signal**

Signals and provides the following functions:

• **Control**

- ON/OFF
- Temperature setting
- Fan speed
- Max 64 FCU

• **Monitoring**

- ON/OFF
- Operation mode
- Temperature setting
- Room temperature
- Local remote controller : permit / prohibit



Modbus® Interface
TCB-IFMB641TLE

• **Modbus®**

The Modbus® interface manages the SMMS-e air conditioning system as a Modbus® device to communicate with the customer's Building Management System.

Accessible to 64 units / groups per one TCB-IFMB641TLE, 15 TCB-IFMB641TLEs on one Modbus® Master (prepared by user).

Signals and provides the following functions:

• **Control**

- ON/OFF
- Temperature setting
- Fan speed
- Max 64 FCU

• **Monitoring**

- ON/OFF
- Operation mode
- Temperature setting
- Room temperature
- Local remote controller : permit / prohibit

1. LonWorks®: Registered trademark Echelon corporation.
 2. BACnet®: ANSI/ASHRAE 135-2008, A data Communication Protocol for Building Automation and Control Networks.
 3. Modbus® is a registered trademark of Schneider E.

Application controls

TCB-PCDM4E



Size: 71 × 85 (mm)

Power peak-cut control

- Feature

The upper limit capacity of the outdoor unit is restricted based on the outdoor power peak selected setting.

- Function

Two control settings are selectable by setting SW07 on the interface P.C. board on the outdoor unit.

TCB-PCMO4E



Size: 55.5 × 60 (mm)

Snowfall fan control

- Feature

The upper limit capacity of the outdoor unit is restricted based on the outdoor power peak selected setting.

External master ON/OFF control

- Feature

The outdoor unit starts or stops the system.

Night operation (Sound reduction) control

- Feature

Sound level can be reduced by restricting the compressor and fan speeds.

Operation mode selection control

- Feature

This control can restrict the selectable operation modes.

TCB-PCIN4E



Size: 73 × 79 (mm)

Error/Operation output control

• **Feature**

Enables external output of error and operation signals.

Compressor operation output

• **Feature**

Enables external signal output for each compressor that is in operation within any given outdoor unit. This feature provides a practical method for calculating total operating times for each compressor.

Operating rate output

• **Feature**

External output of system operating rates enables remote monitoring of operating conditions.

TCB-IFCB-4E2

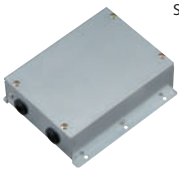

Size: 200 × 170 × 66 (mm)

Remote location ON/OFF control box

• **Feature**

Start and stop of the air conditioner is possible by an external signal and indication of operation/ alarm externally.

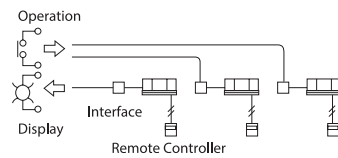

Monitoring

ON/OFF status (for indoor unit)
 Alarm status (system & indoor unit stop)
 ON/OFF command
 Air conditioner can be turned ON/OFF by the external signals.
 The external ON/OFF signals will initiate the signals shown below.

General Purpose Interface

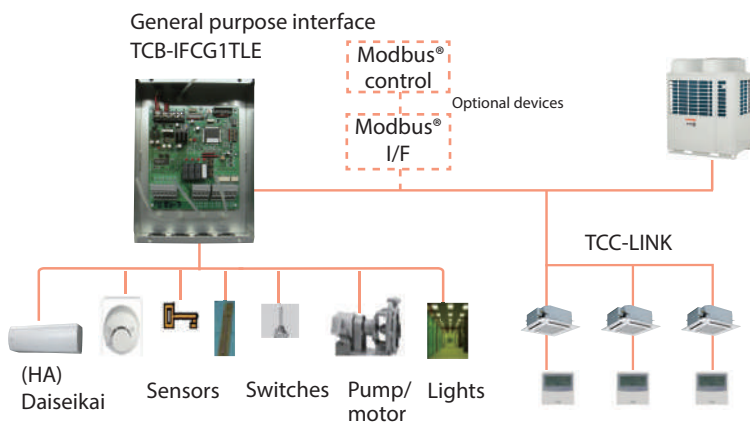

Concept

- Controls the operation status of each indoor unit.
- ON/OFF control of peripheral equipment via the relay point of Toshiba's BMS. (1pt only)

Standard function

Central remote controller and Building Management System devices can control ON/OFF function via digital I/O ports.

Optional function

Control using the following channels: 4-channel relay control, 6-channel digital input, 2-channel analog voltage input and output, and 2-channel temperature measurement functions via Modbus® I/F.

Analog Interface

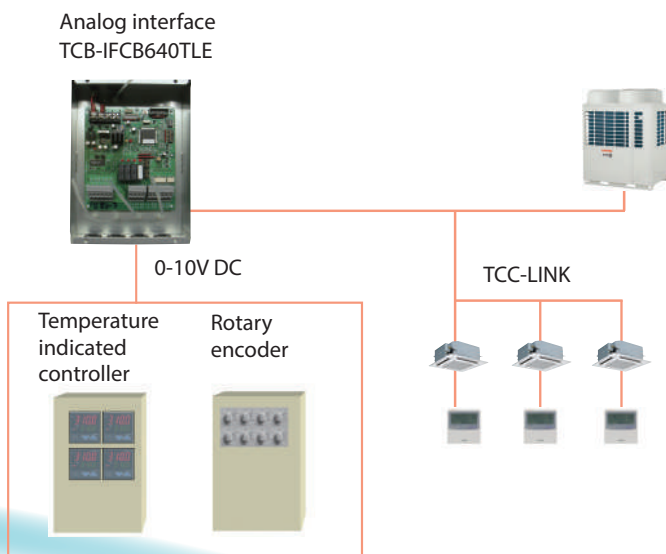

Concept

- Provides access to 64 indoor units.
- Does not require special network knowledge.
- Can control each indoor unit on TCC-LINK, (on/off, temperature setting, airflow volume, louver position), and monitor status based on 0-10V DC voltage input.
- Enables relay control and status monitoring of general-purpose I/F TCB-IFCG1TLE.

TOSHIBA

Air Conditioning for Small and Medium-size Buildings

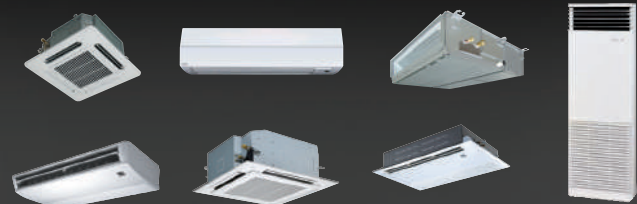

MiNi-SMMS



HIGHER Energy Savings

Industry-leading energy savings

Energy-efficient performance for greater eco-consciousness

Adopting the highly efficient DC twin-rotary compressors and advanced vector-controlled inverters realize EER of 5.71 (under 50% partial load, 4HP). Greater operating performance is now possible when operating under a constant load.

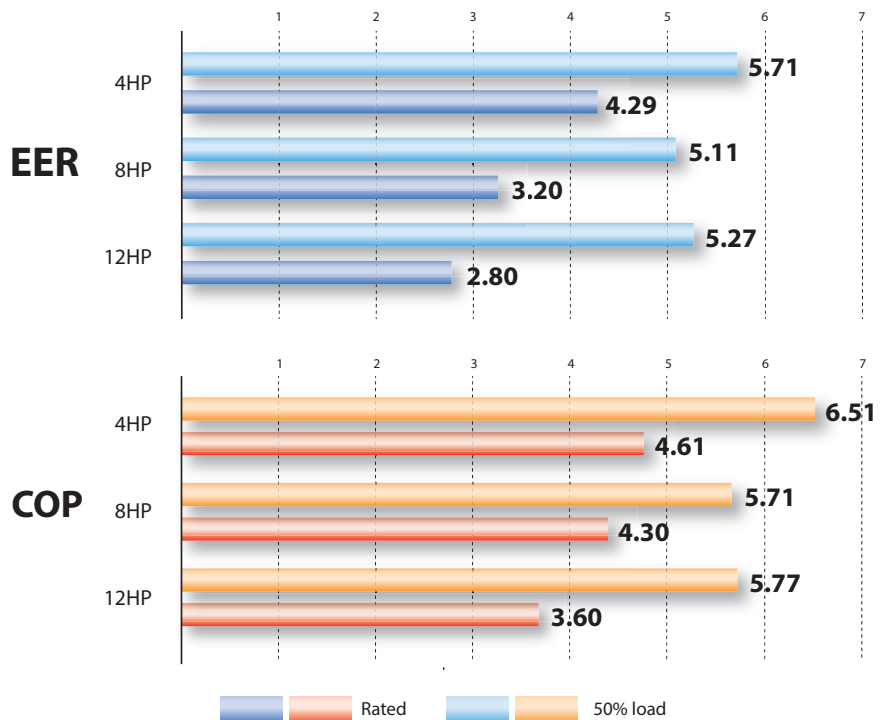

4HP: MCY-MAP0401HT/HT2D 8H P: MCY-MAP0804HT8/HT7 12H P: MCY-MHP1204HT8

*Rated conditions
 Cooling: Indoor air temperature 27°C DB / 19°C WB, Outdoor air temperature 35°C DB
 Heating: Indoor air temperature 20°C DB, Outdoor air temperature 7°C DB / 6°C WB

Toshiba's unique energy-efficient air conditioning innovations and technologies deliver high energy savings.

DC fan motor

- Highly efficient DC motor
- Sine wave drive

Heat exchanger

High-efficiency R410A heat-transfer tube



Configuration of the finned heat-transfer tube

Bat wing fan

High-pressure, low-volume fan



The bat wing fan realizes low sound level

Vector-controlled inverter

The inverter boosts efficiency by controlling R410A and a twin-rotary DC compressor.

Smooth sine curve realizes higher efficiency and less noise.

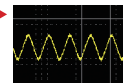

Efficient circuit built-in; new PIM



Vector IPDU control changes the motor current wave to a smooth sine pattern so that noise emitted from the drive units is greatly reduced.

Twin-rotary DC compressor

Increased, wide-range efficiency is realized.



DC driven motor with rare-earth magnet

- Compact
- Higher efficiency
- Higher power motor torque

Precise manufacturing technology in the compression parts

- Higher efficiency (in wide range)
- Higher reliability

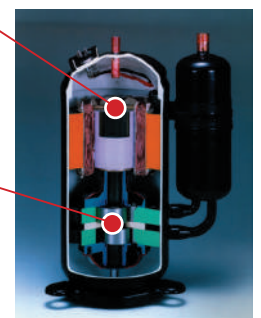

HIGHER Comfort and Ease

Bat wing fan

Fan blade design plays a significant part reducing noise and vibration. Anti-eddy projections and reverse-arc shaped wings reduce air resistance resulting in low operating noise of the outdoor unit.

1-phase outdoor unit

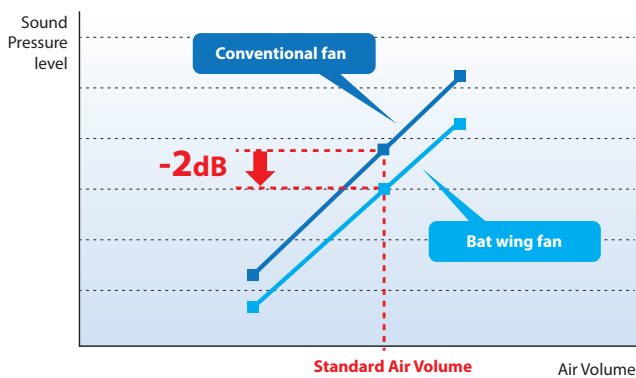

At same air volume, sound is reduced by 2 dB.

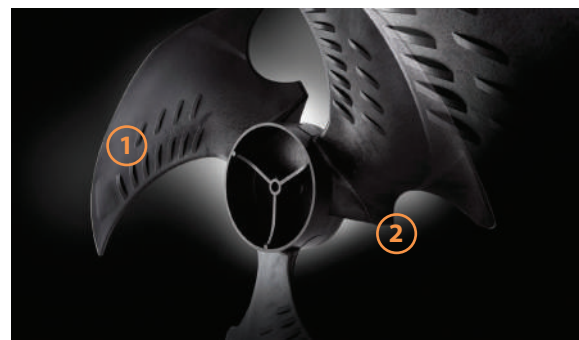

- ① **Anti-eddy projections**
Minimizes the generation of large eddies.
- ② **Reverse-arc-shaped wing**
Reduces rear turbulence due to less pressure loss.

Night operation (sound reduction) control

(With optional PC board (TCB-PCMO4E) and locally supplied timer / switch)

The unit also comes with a night-time low-noise mode, which reduces operating noise at the programmed activation time. (Timer or switch to be locally obtained)

1-phase outdoor units (2 fan chassis) 3-phase outdoor unit

Operation control		Normal	Night
4HP	Cooling	49 dB(A)	46 dB(A)
5HP	Cooling	50 dB(A)	46 dB(A)
6HP	Cooling	51 dB(A)	47 dB(A)

Operation control		Normal	Night
8HP	Cooling	58 dB(A)	50 dB(A)
10HP	Cooling	58 dB(A)	50 dB(A)
12HP	Cooling	61 dB(A)	50 dB(A)

*Sound pressure level: dB (A)



HIGHER Installation and Flexibility

Small footprint

The outdoor unit has a small physical footprint of only 0.29m² to 0.39m², taking up as little space outside as possible.



MiNi-SMMS is suitable for balconies

The outdoor unit is compact and expels exhaust air to the side, so it can be installed even in limited spaces as shown.

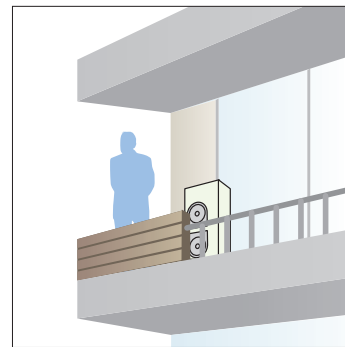

Shortest route design by free branching

Combination of line and header branching is highly flexible, allowing the shortest route possible thereby saving on installation time and cost. Header branching after header branching is only available with Toshiba systems.

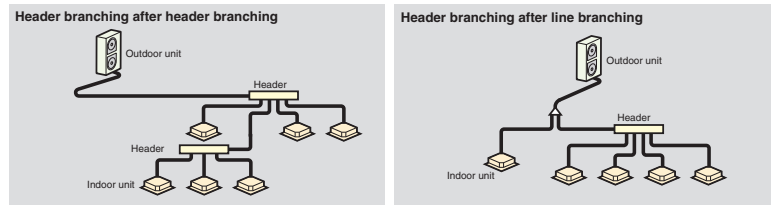

Maximum piping length with PMV kit

Extended refrigerant piping possibilities are possible even with the optional PMV kit installed. 3-phase 6 and 8HP outdoor units have a maximum pipe extension of 180m, and 150m when equipped with PMV kits. On 1-phase outdoor units, piping lengths will differ when PMV kits are used, as shown below.

1-phase outdoor units (2 fan chassis)

When PMV kit is not used

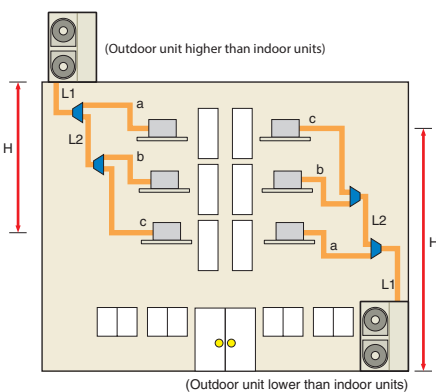

Not used	Piping length	Used
180	Maximum pipe extension (Liquid pipe, real length) Piping section: L1+L2+a+b+c	150
125	Farthest piping length (equivalent length) Piping section: L1+L2+c	80
Height difference		
30	Height between indoor and outdoor units (Outdoor unit higher than indoor units) Piping section: H	30
20	Height between indoor and outdoor units (Outdoor unit lower than indoor units) Piping section: H	20

When PMV kit is used

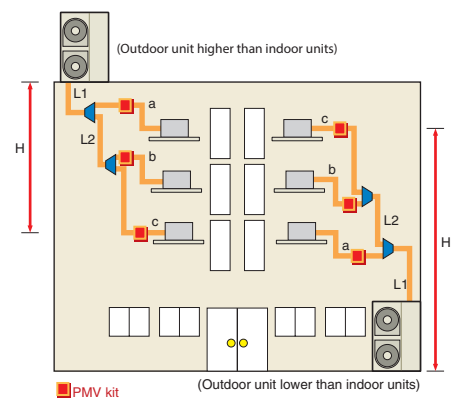







PMV kit

Outdoor Units Line Up

1-phase model

				
Capacity		4HP	5HP	6HP
Energy Label				
Model Name	50 Hz (MCY-)	MHPO404HT-SG	MHPO504HT-SG	MHPO604HT-SG
Cooling capacity*	(kW)	12.1	14.0	15.5
Power supply		1-phase 2 wires 50Hz 220 - 240 V		

1-phase model

				
Capacity		4HP	5HP	6HP
Energy Label				
Model Name	50 Hz (MCY-)	MAP0401TP-SG	MAP0501TP-SG	MAP0601TP-SG
Cooling capacity*	(kW)	12.1	13.3	15.5
Power supply		1-phase 2 wires 50Hz 220 - 240 V		

3-phase model

				
Capacity		8HP	10HP	12HP
Energy Label				
Model Name	50 Hz (MCY-)	MHP0805HT8-SG	MHP1004HT8-1	MHP1204HT8-1
Cooling capacity*	(kW)	22.4	28.0	33.5
Power supply		3-phase 4 wires 50Hz 380V-415V	3-phase 4 wires 50Hz 380V-415V	

*Rated conditions



Cooling : Indoor air temperature 27°C DB / 19°C WB, Outdoor air temperature 35°C DB

Heating : Indoor air temperature 20°C DB, Outdoor air temperature 7°C DB / 6°C WB

Outdoor unit specifications

1-phase model

Technical specifications

Equivalent HP		4HP	5HP	6HP		
Model name		MCY-MHP0404HT-SG	MCY-MHP0504HT-SG	MCY-MHP0604HT-SG		
Energy Label						
Outdoor unit type		Inverter unit				
Power supply		1-phase 50Hz 220 – 240 V / 1-phase 60Hz 220V				
Cooling ^{*1}	Capacity 100%	(kW)	12.1	14.0	15.5	
	Power consumption	(kW)	2.88	3.50	4.35	
	EER (Energy Efficiency Ratio)	Capacity 100%		4.20	4.00	3.56
		Capacity 80%		4.92	4.74	4.24
		Capacity 50%		6.22	6.25	5.73
Heating ^{*1}	Capacity 100%	(kW)	12.5	16.0	18.0	
	Power consumption	(kW)	2.73	3.81	4.50	
	COP (Coefficient of Performance)	Capacity 100%		4.58	4.20	4.00
		Capacity 80%		4.92	4.67	4.52
		Capacity 50%		5.77	5.88	5.88
External dimensions (Height / Width / Depth)		(mm)	1235 / 990 / 390			
Total weight		(kg)	115			
Compressor	Motor output	(kW)	3.75	3.75	3.75	
Fan unit	Motor output	(kW)	0.1 + 0.1			
	Air volume	(m ³ /h)	6030	6210	6410	
Refrigerant piping Specifications	Connecting port dia.	Gas side (OD)	(mm)	15.9		
		Liquid side (OD)	(mm)	9.5		
	Max. pipe extension (Liquid pipe, real length)	(m)	90 (75 ^{*2})			
	Max. pipe length (Real length)	(m)	50 (40 ^{*2})			
	Max. pipe length (Equivalent length)	(m)	60 (50 ^{*2})			
	Max. height between indoor and outdoor units	(m)	Outdoor unit higher than indoor unit: 15 Outdoor unit lower than indoor unit: 15			
Max. no. of connected indoor units			6	6	6	
Sound pressure level (Cooling/Heating) ^{*3}		(dB(A))	50/52	51/54	52/55	

^{*1} Rated conditions Cooling : Indoor air temperature 27°C DB / 19°C WB, Outdoor air temperature 35°C DB
Heating : Indoor air temperature 20°C DB, Outdoor air temperature 7°C DB / 6°C WB
The standard pipe means that equivalent piping length of 7.5 m and standard 0 m piping height difference.



^{*2} When PMV kit is used

^{*3} Sound pressure levels measured in an anechoic chamber in accordance with JIS B 8616.

Outdoor unit specifications

1-phase model

Technical specifications

Equivalent HP			4HP	5HP	6HP	
Model name			MCY-MAP0401TP-SG	MCY-MAP0501TP-SG	MCY-MAP0601TP-SG	
Energy Label						
Outdoor unit type			Inverter unit			
Power supply			1-phase 50Hz 220-240V			
Cooling *1	Capacity 100%	(kW)	12.1	13.3	15.5	
	Power consumption	(kW)	3.18	3.72	4.55	
	EER (Energy Efficiency Ratio)	Capacity 100%		3.81	3.58	3.41
		Capacity 80%		4.92	4.59	4.40
		Capacity 50%		6.85	6.44	6.14
External dimensions (Height / Width / Depth)			(mm) 890 / 900 / 320			
Weight			(kg) 74	74	74	
Compressor	Motor output	(kW)	3.75	3.75	3.75	
Fan unit	Motor output	(kW)	0.1	0.1	0.1	
	Air volume	(m ³ /h)	5000	4850	5000	
Refrigerant piping Specifications	Connecting port dia.	Gas side (OD)	(mm)	15.9		
		Liquid side (OD)	(mm)	9.5		
	Max. pipe extension (Liquid pipe, real length)	(m)	90	90	90	
	Max. pipe length (Real length)	(m)	50	50	50	
	Max. pipe length (Equivalent length)	(m)	60	60	60	
	Max. height between indoor and outdoor units	(m)	15	15	15	
Max. no. of connected indoor units			6	6	6	
Sound pressure level (Cooling/Heating) *3			(dB(A)) 55	53	55	



*1 Rated conditions Cooling : Indoor air temperature 27°C DB / 19°C WB, Outdoor air temperature 35°C DB
 Heating : Indoor air temperature 20°C DB, Outdoor air temperature 7°C DB / 6°C WB
 The standard pipe means that equivalent piping length of 7.5 m and standard 0 m piping height difference.

*2 When PMV kit is used

*3 Sound pressure levels measured in an anechoic chamber in accordance with JIS B 8616.

3-phase model

Technical specifications

Equivalent HP		8HP	10HP	12HP	
Model name	50Hz (MCY-)	MHP0805HT8-SG	MHP1004HT8-1	MHP1204HT8-1	
					
Outdoor unit type		Inverter unit			
Power supply		3-phase 4 wires 50Hz 380 - 415V			
Cooling *1	Capacity 100%	(kW) 22.4	28.0	33.5	
	Power consumption	(kW) 7.00	9.34	11.98	
	Efficiency (iKw/RT)	Capacity 100%	1.10	1.17	1.26
		Capacity 80%	0.84	0.96	1.01
		Capacity 50%	0.53	0.68	0.67
	EER (Energy Efficiency Ratio)	Capacity 100%	3.20	3.00	2.80
		Capacity 80%	4.21	3.67	3.49
Capacity 50%		6.71	5.20	5.27	
External dimensions (Height / Width / Depth) (mm)		1490 / 990 / 390	1825 / 990 / 390		
Total weight (kg)		129	162	6 1 4	
Compressor	Motor output (kW)	3.75	5.60		
Fan unit	Motor output (kW)	0.1 +0.1	0.1 +0.1 +0.1		
	Air volume (m ³ /h)	8000	11100	12000	
Refrigerant piping Specifications	Connecting port dia.	Gas side (OD) (mm)	22.2	25.4	
		Liquid side (OD) (mm)	9.5	12.7	
	Max. pipe extension (Liquid pipe, real length) (m)	100 (100) *2	180 (150) *2		
	Max. pipe length (Real length) (m)	50 (50) *2	100 (65) *2		
	Max. pipe length (Equivalent length) (m)	60 (60) *2	120 (80) *2		
	Max. height between indoor and outdoor units (m)	Outdoor unit higher than indoor unit: 15 Outdoor unit lower than indoor unit: 15			
Max. no. of connected indoor units		8	10	12	
Sound pressure level (Cooling) *3 (dB(A))		58	58	61	

*1 Rated conditions Cooling : Indoor air temperature 27°C DB / 19°C WB, Outdoor air temperature 35°C DB

*2 When PMV kit is used

*3 Sound pressure levels measured in an anechoic chamber

※ Anti-Corrosion protection model : MCY-MAP****HT8ZG, MCY-MAP****HT7ZG, except 10HP, 12HP.

MCY-MHP0404HT, MCY-MHP0504HT, MCY-MHP0604HT

* Model	Diameter of pipe connecting port		Diameter of connecting pipe	
	Liquid side	Gas side	Liquid side	Gas side
MCY-MHP0404HT	Ø 9.52	Ø 15.88	Ø 9.52	Ø 15.88
MCY-MHP0504HT	Ø 9.52	Ø 15.88	Ø 9.52	Ø 15.88
MCY-MHP0604HT	Ø 9.52	Ø 19.05	Ø 9.52	Ø 19.05

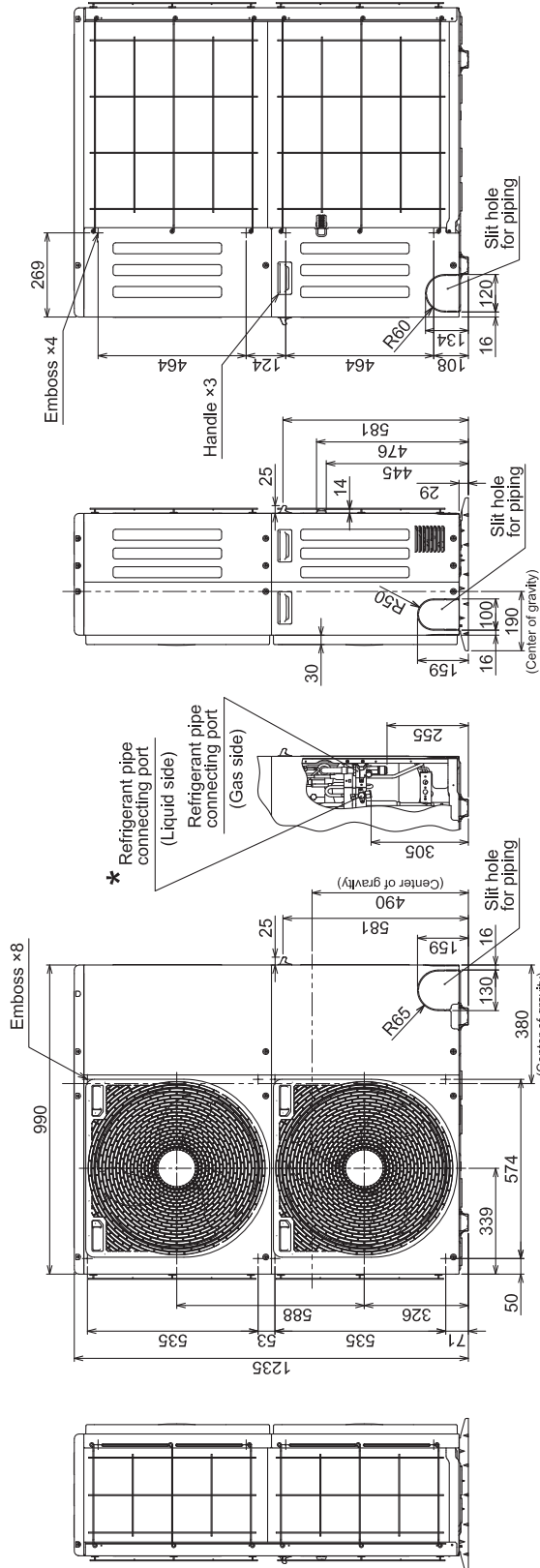
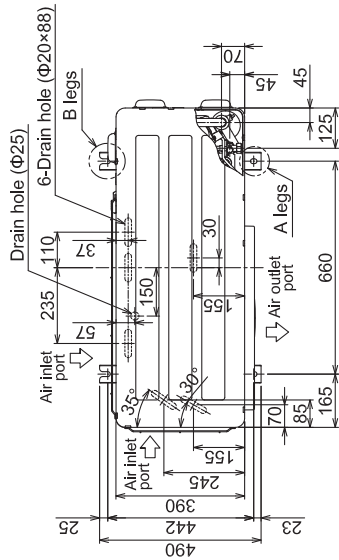
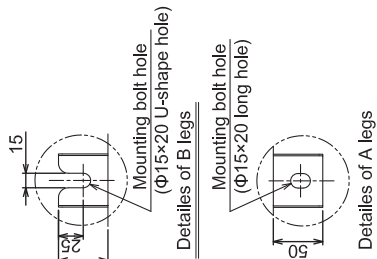

3-phase model :
 MCY-MHP0805HT8-SG

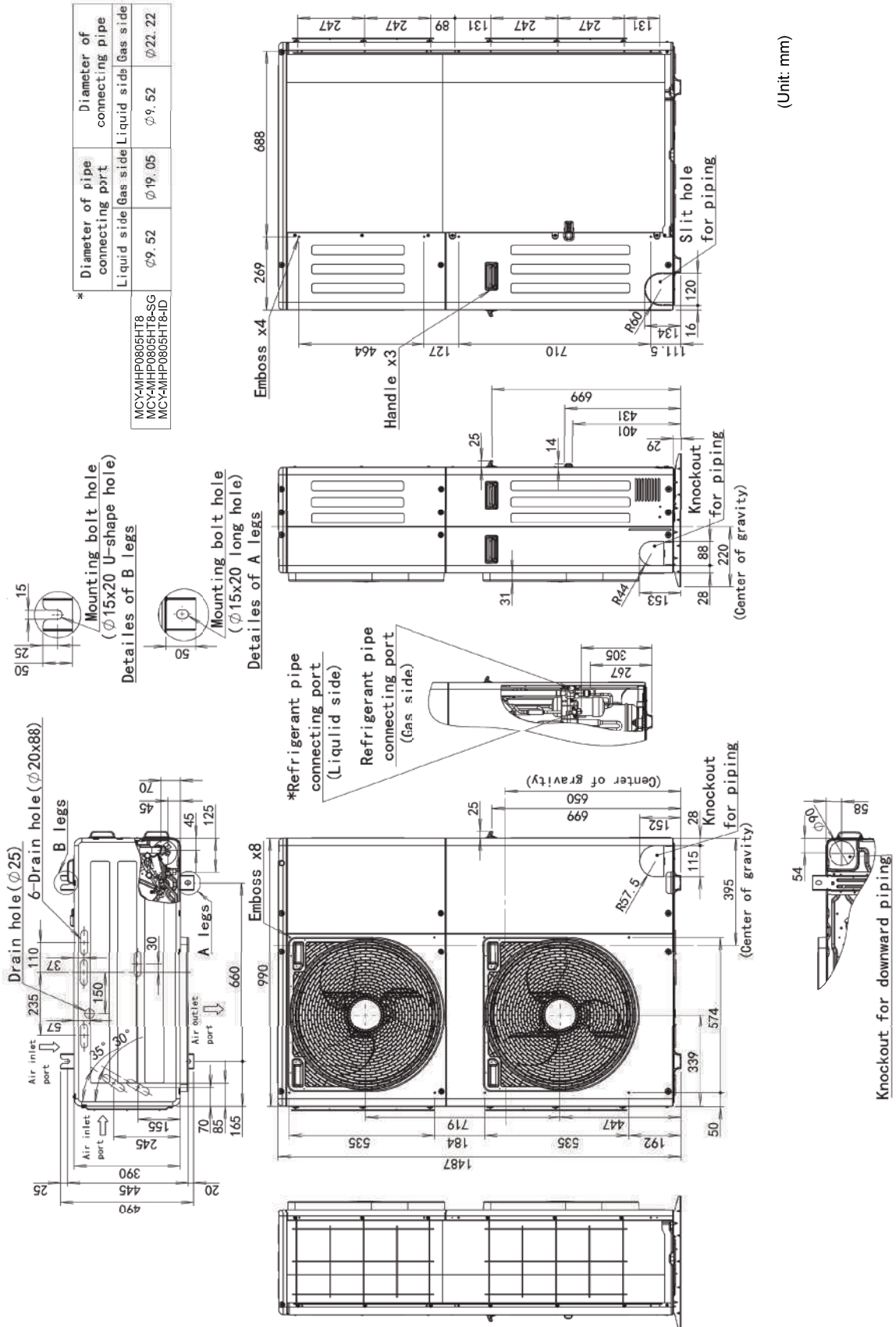

(Unit: mm)

Outdoor drawings

3-phase model :

MCY-MHP1004HT8, MHP1204HT8 (50Hz)

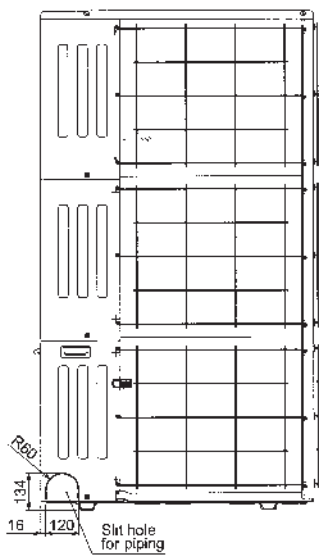
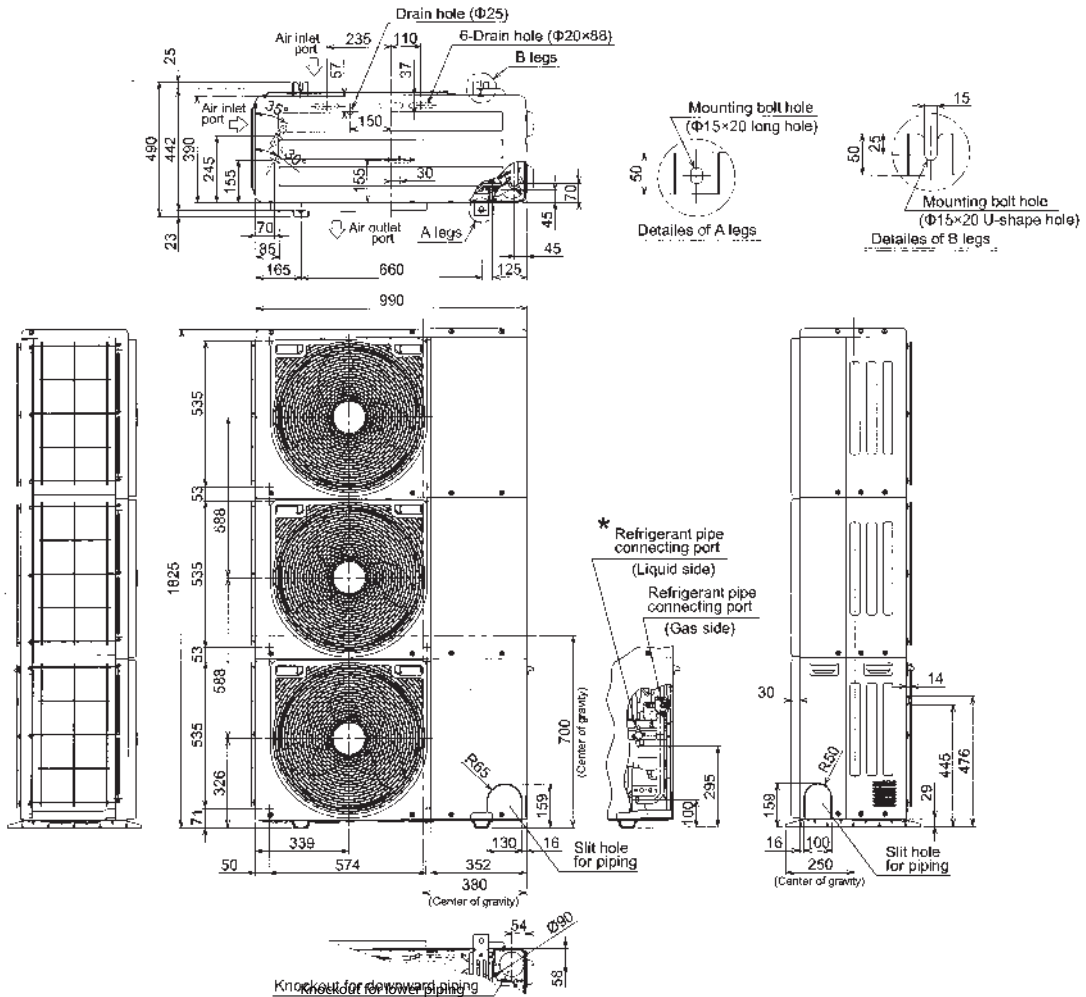

	Diameter of pipe connecting port		Diameter of connecting pipe	
	Liquid side	Gas side	Liquid side	Gas side
MCY-MHP1004HT8	φ 12.7	φ 25.4	φ 12.7	φ 22.2 ^{*1}
MCY-MHP1204HT8	φ 12.7	φ 25.4	φ 12.7	φ 25.4

*1 The diameter of ball valve connecting port on the outdoor unit is 25.4, and the refer please use the accessory joint for installation.

MiNi-SMMS 7

4HP	Model name	MCY-MAP0401TP-SG
	Cooling capacity	12.1 kW
5HP	Model name	MCY-MAP0501TP-SG
	Cooling capacity	13.3kW
6HP	Model name	MCY-MAP0601TP-SG
	Cooling capacity	15.5kW

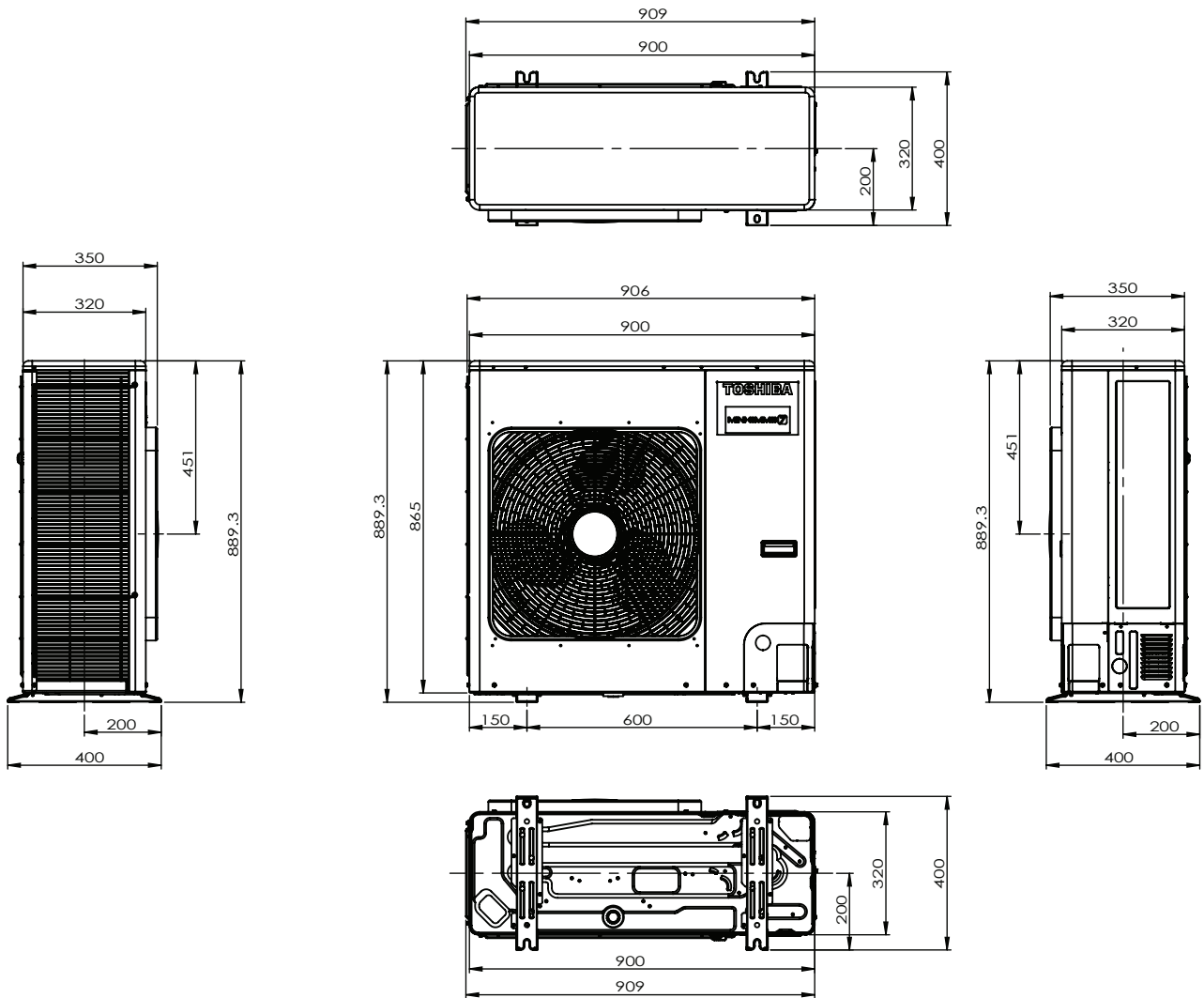

Installation and the use of refrigerants not specified by Toshiba Carrier Corporation

Toshiba refrigeration and air-conditioning units are designed and manufactured on the assumption that the product is used with a specific refrigerant suitable for each unit.

We have recently seen some cases where the type of refrigerant used is different from the one originally installed in the product. Such actions may cause mechanical defects, malfunctions, failures and in some cases result in a serious safety issue. Therefore do not install any refrigerant other than the one specified by Toshiba Carrier Corporation for its respective products.

The type of the refrigerant used for each of our products is shown in the accompanying owners manual, or on the product label attached on the product itself.

Toshiba Carrier Corporation shall not assume any liability for failures, malfunctions or safety in its products if the refrigerant used is different from the one specified.

SAFETY PRECAUTIONS

For operation:

- Before use, read through the operating instructions to ensure proper use.

Concerning the purpose for which the air conditioners are to be used

- The air conditioners presented in this catalogue are air conditioning/heating units to be used solely by general consumers.
 - Do not use these air conditioners for special applications such as for the storage of food items, animals, plants, precision machines or works of art. Doing so may degrade the quality of the items.
 - Do not use these air conditioners for air-conditioning applications in vehicles or ships. Doing so may cause water and/or power leakages.

Precautions for using air conditioners

Concerning the air conditioner's operating conditions and their selection

- (1) Avoid using the air conditioner in the following locations.

- Locations with acidic or alkaline atmospheres (locations at which highly acidic or alkaline air is directly drawn in, such as in hot springs areas from which sulfur gases are given off, or where chemicals, vinegar, exhaust air from burners, etc., are given off) The heat exchangers and other parts may become corroded.
- Locations with atmospheres filled with coolant or other machine oil or steam exhaust (such as at food preparation factories or machine plants). The heat exchangers may corrode; frost may form as a result of heat exchanger malfunction; air conditioner operating performance may be compromised or condensation may form as a result of clogged filters; plastic parts may incur damage; heat-insulation materials may become separated, etc.

Before using an air conditioner in any of the following locations, consult with your dealer or a qualified contractor.

- Locations where vapors from edible oils are given off (such as in bakeries or kitchens and restaurants that use edible oils) ...The air conditioner's operating performance may be compromised or condensation may form as a result of clogged filters, and the plastic parts may incur damage. In line with the prevailing conditions, take countermeasures such as tailoring the installation conditions in accordance with the conditions, using air conditioners designed for kitchens or oil guard filters, etc.
- Locations with disinfectant-induced chlorine atmospheres (water tanks, etc.) The metal parts in the heat exchangers, motors, etc., may become corroded.
- Locations with high salinity (coastal areas, etc.) Corrosion may occur so use outdoor units specifically designed to withstand exposure to salt.

- Locations where power is supplied from independent power generators. The power line frequency and/or voltage may fluctuate, possibly causing the air conditioner to malfunction.
- Locations where high frequencies or electrical noise is generated (from high-frequency welders used for vinyl welding and processing, high-frequency therapeutic devices used for thermotherapy, etc.) The electronic components may be adversely affected, possibly causing the air conditioner to malfunction.
- Locations where electronic equipment is installed. Electrical noise may adversely affect the operation of the electronic equipment.

- (3) Concerning use in locations with high ceilings

- In locations with high ceilings, use of circulators for improving the temperature distribution during heating is recommended.

- (4) Concerning use in high-humidity environments

- When the ceiling-recessed type of indoor unit is installed in a location, such as those described below, and it is very hot and humid inside the ceiling, condensation may form on the external surfaces of the indoor unit and drip down. In such cases, add external heat-insulating materials.
 - Locations such as food preparation sites in which the areas above the ceilings are hot and humid
 - Locations in which outside air is drawn in and routed above the ceiling
 - Above ceilings with a slate roof or tiled roof overhead

- (5) Even when an air conditioner is shut down, it will still consume a small amount of power to protect the unit. If the air conditioner will not be used for a prolonged period, turn OFF the main switch (ground fault circuit breaker). However, before the unit is to be used again, turn ON the main switch (ground fault circuit breaker) for at least 12 hours in order to prevent trouble.



TOSHIBA

TOSHIBA



MASCI

**R-410A
HFC**

ISO 9001 QMS18026/1686
ISO 14001 EMS18012/471
ISO 45001 OHSMS19061/078

Notice : Toshiba is committed to continuously improving its products to ensure the highest quality and reliability standards, and to meet local regulations and market requirements. All features and specifications are subject to change without prior notice.